

**Bias Tee with standard
MS connector**

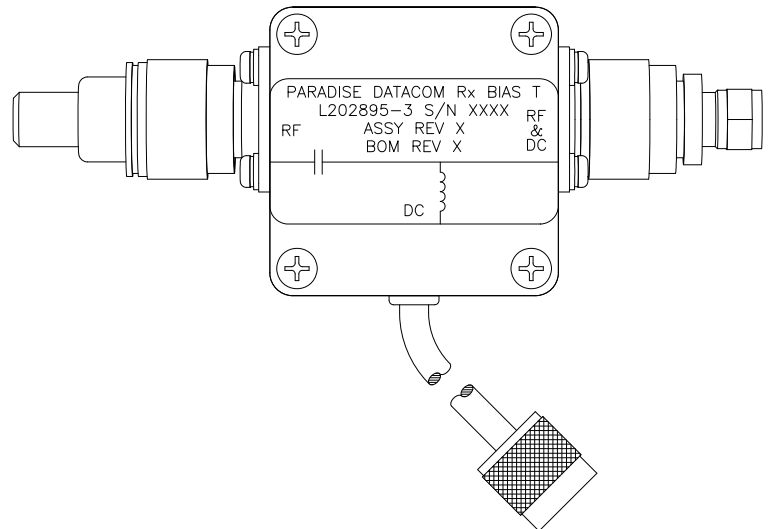

**Bias Tee with optional
TNC connector**

DESCRIPTION

The **Paradise Datacom VSAT Block Up Converter (BUC) Bias Tee** is an integral part of any high power VSAT System.

The addition of a Bias Tee allows the BUC to be powered through the IF cable. The Bias Tee is capable of handling operating currents of up to 6 Amps at 48 VDC, and may be used with the following 48 VDC BUC power levels: 5W-50W C-Band; 10W-35W X-Band and 4W-25W Ku-Band.



The Bias Tee can also be fitted with an optional TNC connector on the DC cable for compatibility with connection to LNBs.

FEATURES

- Integral DC cable with mating circular connector for connection with Paradise Datacom family of High Power single box Block Up Converters.

AT A GLANCE

- Extremely broad-band bias tee;
- Passes 650 KHz FSK control signals, 10 MHz reference and 950-2000 MHz IF while separating the DC current to operate a high power Block Up Converter.

ELECTRICAL SPECIFICATIONS			
PARAMETER	NOTES	LIMITS	UNITS
Frequency Range	IF Reference FSK	950 - 2000 10 - 50 650	MHz MHz KHz
Insertion Loss		≤ 2	dB
Return Loss	Input/Output	≥ 15	dB
DC Current	maximum	6	Amps
DC Voltage	maximum	50	Volts
ENVIRONMENTAL SPECIFICATIONS			
Operating Temperature Range		-40 to +60	°C
Storage Temperature Range		-55 to +90	°C
Humidity	condensing	100	%
MECHANICAL SPECIFICATIONS			
Connectors (L202895-1)	IFL Input IF Output DC Output	Type N (F) Type N (M) MS3106A20-29S*	
Size	W x H x D	1.99 x 1.99 x 1.22 50.5 x 50.5 x 31	in mm
OPTIONS			
PART NO.	CONNECTOR	DESCRIPTION	
L202895-2	IFL Input IF Output DC Output	Type N (F) Type N (F) MS3106A20-29S*	
L202895-3	IF Input, DC Output IFL Output DC Input	Type F (M) Type F (F) TNC (M) with 15 ft. (4.6m) cable	
L202895-4	IF Input, DC Output IFL Output DC Input	Type F (M) Type F (F) TNC (M) with 2 ft. (0.6m) cable	
L202895-5	IF Input, DC Output IFL Output DC Input	Type N (F) Type N (F) TNC (M) with 2 ft. (0.6m) cable	
L202895-11	IFL Input IF Output DC Output	Type N (F) Type N (M) MS3106F18-4S [†]	

* With 1 ft. (0.3 m) cable; mates with Paradise Datacom 3100-series C- and Ku-band BUCs.

[†] With 1 ft. (0.3m) cable; mates with Paradise Datacom VSAT-series C-, X- and Ku-band BUCs.

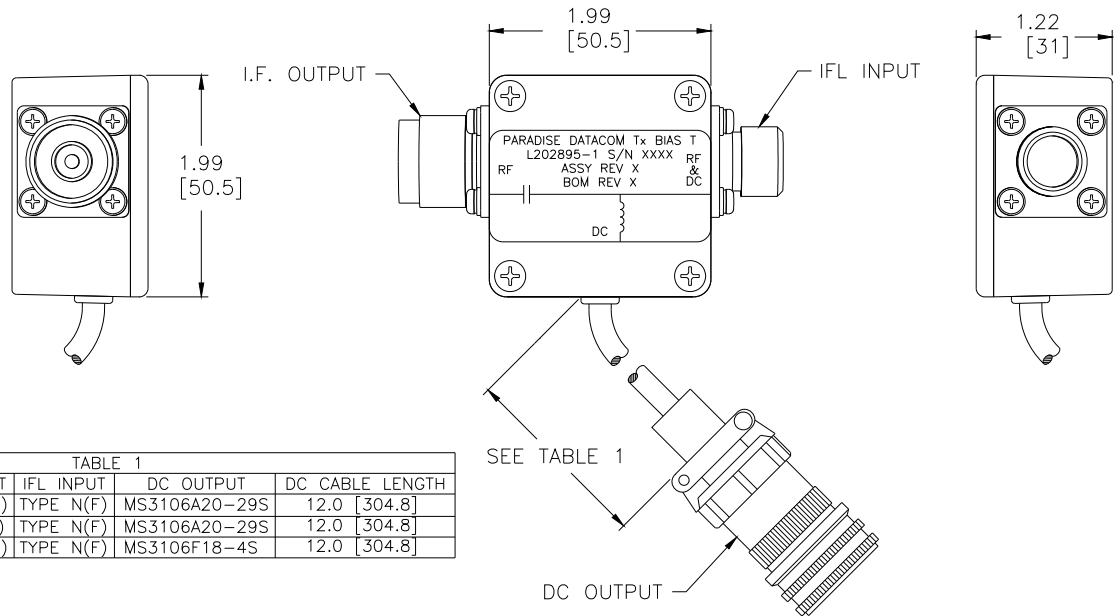

ASSY	IF OUTPUT	IFL INPUT	DC OUTPUT	DC CABLE LENGTH
L202895-1	TYPE N(M)	TYPE N(F)	MS3106A20-29S	12.0 [304.8]
L202895-2	TYPE N(F)	TYPE N(F)	MS3106A20-29S	12.0 [304.8]
L202895-11	TYPE N(M)	TYPE N(F)	MS3106F18-4S	12.0 [304.8]

Bias Tee with standard MS connector (202895-1, 202895-2 or 202895-11)

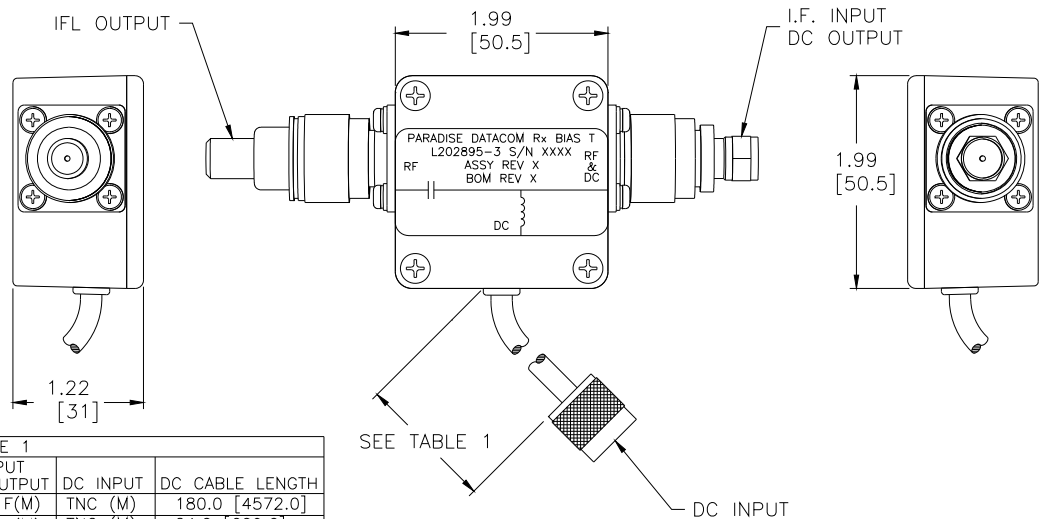

ASSY	IFL OUTPUT	IF INPUT DC OUTPUT	DC INPUT	DC CABLE LENGTH
L202895-3	TYPE F(F)	TYPE F(M)	TNC (M)	180.0 [4572.0]
L202895-4	TYPE F(F)	TYPE F(M)	TNC (M)	24.0 [609.6]
L202895-5	TYPE N(F)	TYPE N(F)	TNC (M)	24.0 [609.6]

Bias Tee with optional TNC connector (202895-3, 202895-4 or 202895-5)