

100W Ku-Band 1:2 Phase Combined SSPA System with FPRC-1200 Controller

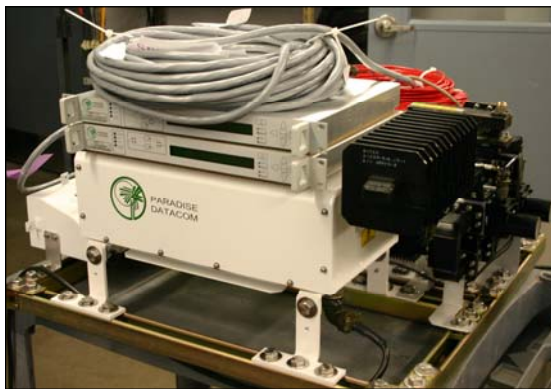

125W Ku-Band 1:1 Phase Combined SSPB System with FPRC-1100 Controller and RCP2-1100 Controller for L-Band redundancy



1 kW C-Band, 1:1 Phase Combined High Power Outdoor SSPA System

DESCRIPTION

Paradise Datacom's family of outdoor packaged, phase combined solid state power amplifier (SSPA) systems provide the highest degree of redundancy and system reliability. Phase Combined amplifier systems can be configured using Paradise Datacom's High Power Outdoor amplifiers.

1:1 Phase Combined Systems are an economical solution to providing high output power capability with soft-fail redundancy. 1:2 Phase Combined Systems can provide full output power redundancy to mission critical applications which cannot tolerate any decrease in output power capability.

Both 1:1 and 1:2 Phase Combined Systems utilize a signal box through which all RF and L-band input signals are distributed. This ensures that any reference signal is modulated to each amplifier at the same frequency, and that the phase adjustment is optimized.

FEATURES

- Extremely High Power Density:
 - 1.2 kW C-Band;
 - 1.2 kW S-Band;
 - 600 W X-Band;
 - 500 W Ku-Band
- Universal Power Factor Corrected Power Supply
- System Output Power Monitor

OPTIONS

- Reflected Power Monitor
- L-Band Input operation
- SSPA and Controller Remote Panels
- Auxiliary / Maintenance Output Switch
- Cold Standby Amplifier Operation for Prime Power Savings
- Custom Configurations



1:1 Phase Combined / Redundant System

The 1:1 Fixed Phase Combined Redundant System is a popular system architecture that enables two Solid State Power Amplifiers to operate as a normal 1:1 redundant system or a phase combined system. The basic system topology is very similar to a 1:1 redundant system and is shown in the block diagram. An additional switch is included which allows either amplifier to be individually connected to the antenna or connect both amplifiers to a waveguide combiner.

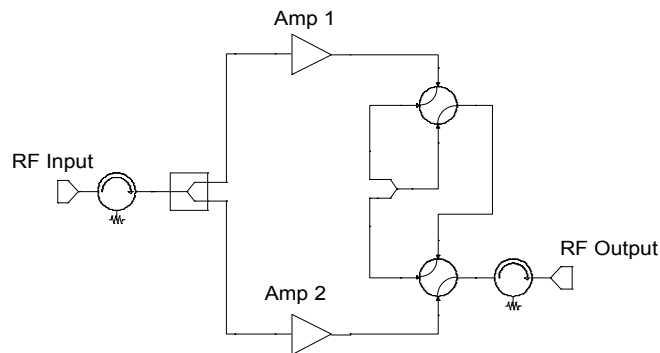

1:1 Phase Combined System Simplified Block Diagram

1:2 Phase Combined / Redundant System

The 1:2 Phase Combined Redundant System is a system architecture that enables Solid State Power Amplifiers to achieve higher output power levels while building in a level of redundancy. The basic system topology is similar to a 1:2 redundant system shown in the block diagram below. Amplifiers #1 and #3 are normally online. The outputs of #1 and #3 are directed by the waveguide switches into a low loss power combiner. In the event of a failure of either on line amplifier, the standby amplifier, #2, can be switched in place of either #1 or #3 and the system maintains **full output power**.

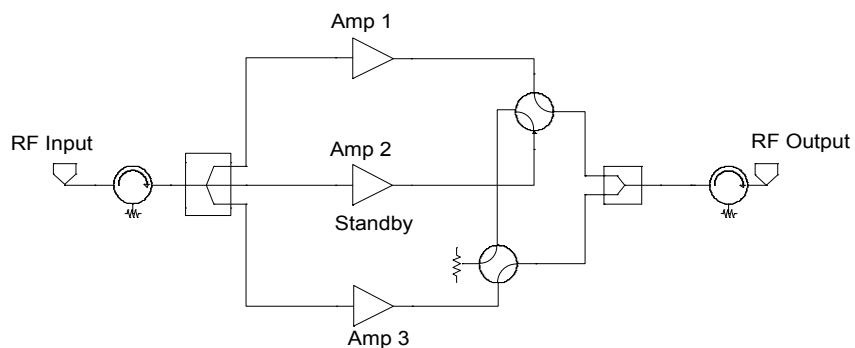

1:2 Phase Combined System Simplified Block Diagram



Outdoor Systems are configured with Paradise Datacom's popular High Power Outdoor or Compact Outdoor SSPA packages



High Power Outdoor Enclosure
Output Power Levels

S-Band: 400W - 600W
C-Band: 400W - 600W
X-Band: 350W - 500W
Ku-Band: 200W - 250W



Compact Outdoor
Output Power Levels

S-Band: 50W - 300W
C-Band: 30W - 300W
X-Band: 25W - 250W
Ku-Band: 10W - 125W

System Output Power Capacity

Due to the output waveguide and switches, there is always some residual loss in the output of phase combined HPA systems. This results in slightly less than the ideal 3dB power addition to the output power of a single HPA unit.

On 1:1 phase combined systems, the typical additive output power is 2.70 dB above the output power of a single HPA. On 1:2 phase combined systems, the typical additive output power is 2.50 dB above the output power of a single HPA.

For example, a 125W Ku-Band Compact Outdoor SSPA in a 1:1 phase combined system would have the following output power:

Single Compact Outdoor HPA:	$P_{1dB} = 50.0 \text{ dBm}; P_{sat} = 51.0 \text{ dBm}$
1:1 phase combined system:	$P_{1dB} = 52.7 \text{ dBm}; P_{sat} = 53.7 \text{ dBm}$



L-Band Operation

Paradise Datacom Phase Combined HPA Systems can be configured for L-Band Input operation. For optimum RF phase combining over the entire bandwidth of a communication amplifier, the frequency translation part of the system must be separated from the phase combining loop. Therefore, systems with L-Band input are configured with a separate 1:1 system of L-Band Block Up Converters that feed the 1:1 or 1:2 Phase Combined HPA system. If L-Band redundancy is not required, the system can be configured with a single thread L-Band Block Up Converter.

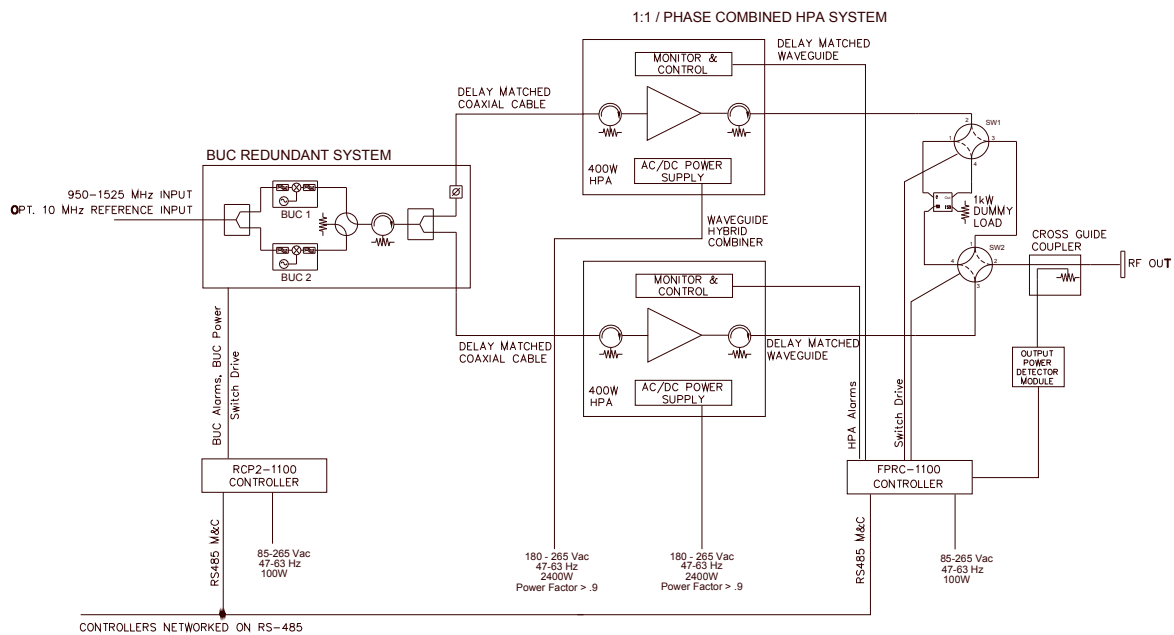

The Block Up Converter system is housed in a weather-proof enclosure (shown below) and controlled by an indoor RCP2-1100 Redundant Controller. The Up Converters can be configured with internal reference oscillators or external reference oscillators. The Paradise Datacom ZBUC™ architecture allows a converter that is fitted with an internal reference oscillator to automatically detect and switch to an externally applied 10 MHz reference signal.





L-Band Operation

The addition of a ZBUC™ to an Outdoor SSPA typically increases the gain by 2-4 dB. The advantages of ZBUC™ technology include:

- ZBUC™ can detect and switch to an externally supplied reference.
- Optional internal high stability (10MHz) reference.
- ZBUC™ can lock to an externally supplied reference of 5, 10, 20, 25, or 50 MHz without modification.
- ZBUC™ can accept a wide range of external reference power (-10dBm to +5 dBm)
- ZBUC™ can accept FSK monitor and control signal via the IFL for complete amplifier remote control.

Available Frequency Plans

Band	Frequency Band	IF Input	LO Frequency	RF Output	Gain Change
C	Standard C-Band	950 - 1525 MHz	4.900 GHz	5.850 - 6.425 GHz	0-4 dB
C	Extended C-Band	950 - 1825 MHz	4.900 GHz	5.850 - 6.725 GHz	0-4 dB
C	Palapa Band	950 - 1250 MHz	5.475 GHz	6.425 - 6.725 GHz	0-4 dB
C	Insat Band	950 - 1250 MHz	5.775 GHz	6.725 - 7.025 GHz	0-4 dB
C	Extended C-Band 2	950 - 1675 MHz	4.800 GHz	5.750 - 6.475 GHz	0-4 dB
X	Standard X-Band	950 - 1450 MHz	6.950 GHz	7.900 - 8.400 GHz	0-2 dB
Ku	Standard Ku-Band	950 - 1450 MHz	13.050 GHz	14.00 - 14.50 GHz	0-2 dB
Ku	Extended Ku-Band	950 - 1700 MHz	12.800 GHz	13.75 - 14.50 GHz	0-2 dB

Electrical Specifications for Outdoor SSPA with ZBUC™

PARAMETER	NOTES	LIMITS				UNITS
Gain	Nominal setting	75				dB
Gain Flatness	full band (C-,X-,Ku-bands)	±2.0				dB
Gain Slope	per 40 MHz (C-,X-,Ku-bands)	±0.5				dB/40 MHz
Gain Adjusted Range		20				dB
	Typical C-Band Adj. Range	60 - 80				dB
	Typical Ku-Band Adj. Range	57 - 77				dB
Gain Stability	-40 to +60 °C	±1.5				dB
Phase Noise	Offset frequency from carrier	<u>Absolute max.</u>	<u>C-band (typ.)</u>	<u>X-band (typ.)</u>	<u>Ku-band (typ.)</u>	
	10 Hz	-30	-60	-60	-50	dBc/Hz
	100 Hz	-60	-80	-75	-65	dBc/Hz
	1 KHz	-70	-80	-75	-72	dBc/Hz
	10 KHz	-80	-85	-100	-90	dBc/Hz
	100 KHz	-90	-120	-110	-110	dBc/Hz
	1 MHz	-90	-125	-122	-120	dBc/Hz
Spurious	In-Band Signal Related (C-/Ku-Band)					dBc
	(Extended C-Band)					dBc
	Close to Carrier Spurious (≤ 20 MHz)					dBc
	Local Oscillator					dBm
	Non-Signal Related					dBm
Noise Figure	At 75 dB gain setting	20				dB
Input VSWR	L-Band	1.5 : 1				
Internal Reference Option	Reference accuracy @ 25 °C	±1 • 10 ⁻⁸				
	Reference Stability over Temperature (-40 to +40 °C)	±1 • 10 ⁻⁹				



System Controllers

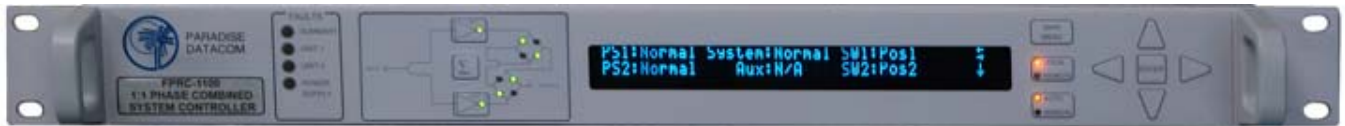

FPRC-1100 1:1 Phase Combined System Controller

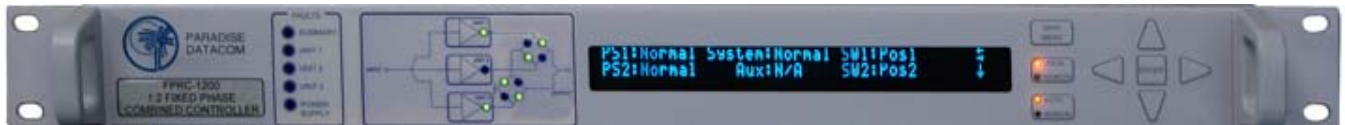

FPRC-1200 1:2 Phase Combined System Controller

The FPRC-1X00 is the heart of the Redundant SSPA System. It provides an extremely user friendly interface for complete monitor and control of the high power amplifiers. The front panel mimic display shows the on-line amplifiers and the switch positions. Fault lights are provided for easy indication of system status.

All FPRC-1X00 monitor and control is available locally at the front panel LCD display, as well as remotely by the RS232 , RS485, or Ethernet interface ports. Audible alarms and a full compliment of parallel I/O signal are available at the rear panel of the FPRC-1X00.

The FPRC-1X00 System Controller allows the Phase Combined System of amplifiers to be controlled as if it were a single SSPA. The FPRC is the single point of interface for either local, front panel, or remote control. System monitor and control capability include gain adjustment, output power monitoring (dBm or Watts), and alarms.

The FPRC-1X00 is a 1RU indoor control unit that contains its own internal redundant components including fully redundant power supplies.

Note: Systems can be configured without the use of a system controller. Consult the factory for operation of phase combined systems without a system controller.



General System Specifications

PARAMETER	NOTES	LIMITS	UNITS
Gain	minimum	70	dB
Gain Flatness	minimum (units with L-Band input) full band (all except Extended C-Band) Extended C-Band units	67 ±1.0 ±1.5	dB dB dB
Gain Slope	per 40 MHz	±0.3	dB/40 MHz
Gain Variation vs. Temperature	-40 to +60°C	±1.0	dB
Gain Adjustment	0.1 dB resolution adjustable by either serial or analog voltage input: 0.5 to 2.5 VDC	20	dB
Intermodulation Distortion	3dB back off relative to P _{1dB}	-25	dBc
AM/PM Conversion	(@ rated P _{1dB}) (@ P _{1dB} -3dB)	3.5 1.0	°/dB °/dB
Spurious Harmonics	(@ rated P _{1dB}) (@ rated P _{1dB} -3dB) (C-, X-, Ku-bands) (@ rated P _{1dB} -3dB) (S-band)	-60 -50 -30	dBc dBc dBc
Input/Output VSWR	All units except Extended C-Band Extended C-Band units	1.30:1 1.50:1	
Noise Figure	at maximum gain (C-, X-, Ku-bands) at maximum gain (S-band)	10 8	dB dB
Group Delay (per 40 MHz segment)	Linear Parabolic Ripple	0.01 0.003 1.0	ns/MHz ns/MHz ² ns p-p
Transmit Band Noise Output Power Density	TX Band RX Band (C- or Ku-bands) RX Band (X-Band) RX Band (S-Band)	-75 -150 -100 See options	dBW/4 KHz dBW/4 KHz dBW/4 KHz
Receive Band Noise Output Power Density	S-Band, with optional filter S-Band, without optional filter	-155 -95	dBW/4 KHz dBW/4 KHz
Residual AM Noise	0 - 10 KHz 10 KHz - 500 KHz 500 KHz - 1 MHz	-45 -20 (1.25 + log F) -80	dBc dBc dBc
Phase Noise	Offset frequency from carrier 10 Hz 100 Hz 1 KHz 10 KHz 100 KHz 1 MHz	-90 -100 -110 -120 -125 -130	dBc/Hz dBc/Hz dBc/Hz dBc/Hz dBc/Hz dBc/Hz

Environmental

Operating Temperature	Ambient	-40 to +60	°C
Relative Humidity	condensing	100	%
Cooling System	integrated	Forced air	

Mechanical

Size, High Power Outdoor	width X length X height	21.0 X 27.95 X 13.5	inches
Size, Compact Outdoor	width X length X height	533 X 710 X 343 10.0 X 19.5 X 6.50 254 X 495 X 165	mm inches mm
Weight, High Power Outdoor		125 (57)	lbs.(kg)
Weight, Compact Outdoor	Base unit (<200W S/C-bands; <100W Ku) Base unit (≥200W S/C-bands; ≥100W Ku) Base unit (<200W X-Band) Base unit (≥200W X-Band) With Internal zBUC	36 (16.4) ± 3% 44 (20.0) ± 3% 46.7 (21.1) ± 3% 54.9 (25.0) ± 3% +1.7 (0.8)	lbs.(kg) lbs.(kg) lbs.(kg) lbs.(kg) lbs.(kg)
Finish		Paint	White; powder coat

Specifications are subject to change.



Part Number Configuration, High Power Outdoor System

HPA 2 W

Band
S - S-Band
C - C-Band
X - X-Band
K - Ku-Band

Power Level (in Watts)
S-Band
400, 500, 600
C-Band
400, 500, 600
X-Band
350, 500
Ku-Band
200, 250

Frequency Sub Band
S-Band
A - 2.020 - 2.120 GHz
B - 2.200 - 2.300 GHz
C-Band
A¹ - 5.85 - 6.425 GHz
B¹ - 5.85 - 6.725 GHz
C - 5.75 - 6.670 GHz
E^{1,2} - 6.425 - 6.725 GHz (Palapa)
F^{1,2} - 6.725 - 7.025 GHz (Insat)
G¹ - 5.750 - 6.475 GHz
H¹ - 5.715 - 5.790 GHz
J¹ - 5.740 - 6.650 GHz
V^{1,3} - 5.85 - 6.725 GHz
X-Band
A¹ - 7.90 - 8.40 GHz
B - 7.50 - 8.50 GHz
D - 7.70 - 8.40 GHz
E - 7.75 - 8.50 GHz
Ku-Band
A¹ - 14.00 - 14.50 GHz
B¹ - 13.75 - 14.50 GHz

¹ Available with optional ZBUC.
² Available in 400W and 500W power levels.
³ With 1.3:1 VSWR.

Configuration Modifier
XXX = Standard
SXX = Input Sample
XVX = Reflected Power Monitor
XXR* = Receive Band Reject Filter

* S-Band only. 500W and 600W units require an external filter.

System Configuration
E = 1:2, Input Splitter, FPRC-1200*
G = 1:1, Input Splitter, FPRC-1100*
J = 1:2, Input Splitter, Internal control
S = System (Custom)

* Standard Cable Length of 100 ft. (30m) with FPRC

Block Up Converter
B = BUC (Custom)
M = Internal Reference ZBUC
P = External Reference ZBUC
X = None

Package
W = Weather proof (NEMA)

Example - A 400W S-Band 1:2 Fixed Phase Combined High Power Outdoor SSPA System with a FPRC-1200 controller and no block up converter is part number: **HPAS2400AWXEXXX**.



Part Number Configuration, Compact Outdoor Systems

HPA 2 C

Band
S - S-Band
C - C-Band
X - X-Band
K - Ku-Band

Power Level (in Watts)
S-Band
050, 100, 200 or 300
C-Band
030, 040, 050, 075, 100, 140, 200, 250 or 300
X-Band
025, 030, 060, 075, 100, 140, 200, or 250
Ku-Band
010, 020, 025, 035, 040, 050, 070, 100, or 125

Frequency Sub Band
S-Band
A - 2.020 - 2.120 GHz
B - 2.200 - 2.300 GHz
C-Band
A¹ - 5.85 - 6.425 GHz
B¹ - 5.85 - 6.725 GHz
C - 5.75 - 6.670 GHz
E¹ - 6.425 - 6.725 GHz (Palapa)
F¹ - 6.725 - 7.025 GHz (Insat)
G¹ - 5.750 - 6.475 GHz
H¹ - 5.715 - 5.790 GHz
J¹ - 5.740 - 6.650 GHz
V^{1,2} - 5.85 - 6.725 GHz
X-Band
A¹ - 7.90 - 8.40 GHz
B - 7.50 - 8.50 GHz
D - 7.70 - 8.40 GHz
E - 7.75 - 8.50 GHz
Ku-Band
A¹ - 14.00 - 14.50 GHz
B¹ - 13.75 - 14.50 GHz

¹ Available with optional ZBUC.
² With 1.3:1 VSWR.

Configuration Modifier
XXX = Standard
KXX¹ = 110 VAC Option
XMX = MS-Connector Covers
XR² = Receive Band Reject Filter
XS² = MS-Connector Covers & Receive Band Reject Filter
XT³ = Transmit Band Filter
XU³ = MS-Connector Covers & Transmit Band Filter
XXA = Side-mount AC Input, Location 'A'
XXD = 48 VDC Input
XXF = Side-mount 48V Input, Location 'A'

¹ Available in C- and X-Band models ≥140W and Ku-band models ≥100W.
² S-Band only.
³ X-Band only.

System Configuration
E = 1:2, Input Splitter, FPRC-1200¹
G = 1:1, Input Splitter, FPRC-1100¹
J = 1:2, Input Splitter, Internal control
S = System (Custom)

¹ Standard Cable Length of 100 ft. (30m) with FPRC

Block Up Converter
B = BUC (Custom)
M = Internal Reference ZBUC
P = External Reference ZBUC
X = None

Package
C = Standard Compact Outdoor

Example - A 1:1 phase combined standard frequency 70W Ku-Band Compact Outdoor SSPA system with input splitter and internal control with an external reference BUC is part number: **HPAK2070ACBPXXX**.