



**1.1 kW C-Band,
1:1 Indoor Rack Mount**



**600W C-Band,
1:2 Indoor Rack Mount
Phase Combined System**

DESCRIPTION

Paradise Datacom's family of indoor packaged, phase combined solid state power amplifier (SSPA) systems provide the highest degree of redundancy and system reliability. Phase Combined amplifier systems can be configured using any combination of Paradise Datacom's Indoor Packaged amplifiers.

1:1 Phase Combined Systems are an economical solution to providing high output power capability with soft-fail redundancy.

1:2 Phase Combined Systems can provide full output power redundancy to mission critical applications which cannot tolerate any decrease in output power capability.

FEATURES

- Extremely High Power Density:
 - 1.1 kW C-Band
 - 1.1 kW S-Band
 - 1.0 kW X-Band
 - 500 W Ku-Band
- True Redundant Chassis Architecture
- Universal Power Factor Corrected Power Supply
- System Output Power Monitor
- 1RU FPRC-1100 / FPRC-1200 System Controller

OPTIONS

- Reflected Power Monitor
- L-Band Input operation
- SSPA and Controller Remote Panels
- Auxiliary / Maintenance Output Switch
- Cold Standby Amplifier Operation for Prime Power Savings
- External Exhaust Air Ducting Kit
- Custom Configurations

SPECIFICATIONS

- 4 RU SSPA Chassis:
 - 19.0 X 7.0 X 28.0
 - 483 X 178 X 711
 - 75 lbs (34 kg) \leq 250W
 - 100 lbs (45 kg) $>$ 250W
- 6 RU SSPA Chassis:
 - 19.0 X 10.47 X 30.0
 - 483 X 266 X 762
 - 180 lbs (82 kg)
- 3 RU Power Supply:
 - 19.0 X 5.25 X 15.44
 - 483 X 134 X 433
 - 50 lbs (23 kg)



1:1 Phase Combined / Redundant System

The 1:1 Fixed Phase Combined Redundant System is a popular system architecture that enables two Solid State Power Amplifiers to operate as a normal 1:1 redundant system or a phase combined system. The basic system topology is very similar to a 1:1 redundant system and is shown in the block diagram. An additional switch is included which allows either amplifier to be individually connected to the antenna or connect both amplifiers to a waveguide combiner. The system includes an integrated input sample port along with system level output power detection.

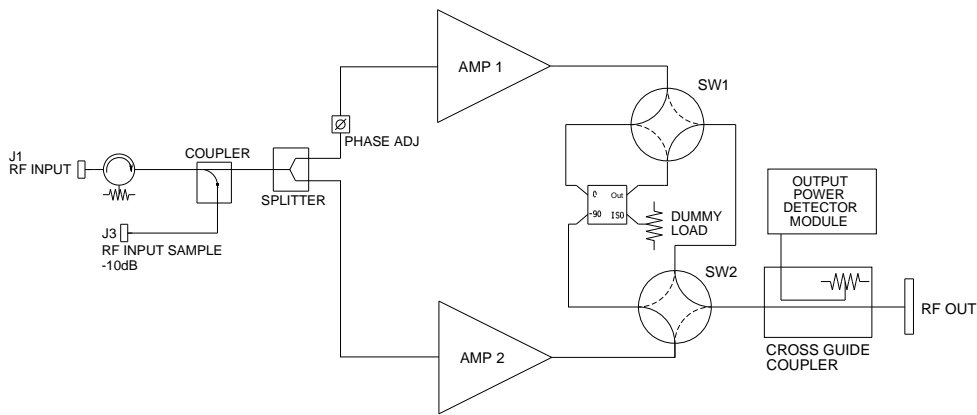

1:1 Phase Combined System Simplified Block Diagram

1:2 Phase Combined / Redundant System

The 1:2 Phase Combined Redundant System is a system architecture that enables Solid State Power Amplifiers to achieve higher output power levels while building in a level of redundancy. The basic system topology is similar to a 1:2 redundant system shown in the block diagram below. Amplifiers #1 and #3 are normally online. The outputs of #1 and #3 are directed by the waveguide switches into a low loss power combiner. In the event of a failure of either on line amplifier, the standby amplifier, #2, can be switched in place of either #1 or #3 and the system maintains **full output power**. The system includes an integrated input sample port along with system level output power detection.

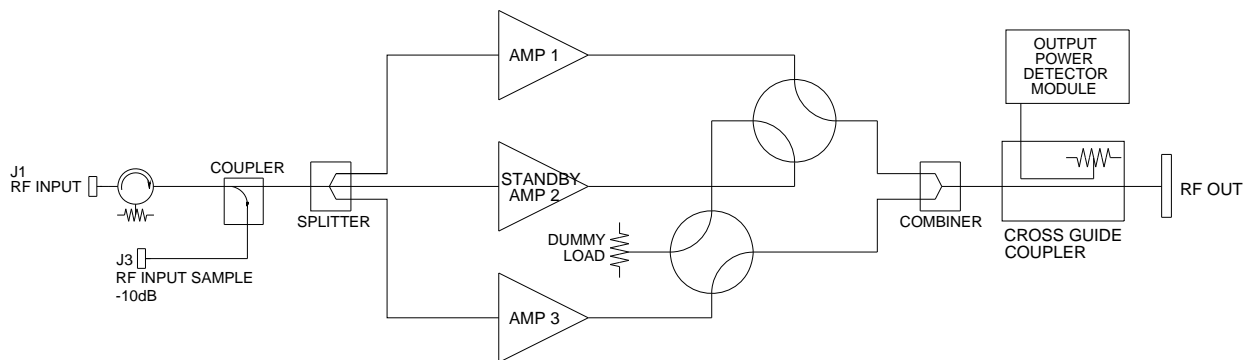

1:2 Phase Combined System Simplified Block Diagram



Indoor Systems are configured with Paradise Datacom's popular 3 or 4 RU chassis ...



Single 3RU Chassis Output Power Levels

S Band: 50W - 300W
C Band: 25W - 300W
X Band: 60W - 200W
Ku Band: 10W - 200W



Single 4RU Chassis Output Power Levels

S Band: 50W - 600W
C Band: 50W - 600W
X Band: 50W - 500W
Ku Band: 35W - 250W

... or with Paradise Datacom's 6 RU chassis and a 3 RU N+1 power supply.



Single 6RU Chassis Output Power Levels

S Band: 1.1kW
C Band: 750W - 1.1 kW
X Band: 700W - 1.0 kW
Ku Band: 400W - 500W

The 6 RU chassis is a truly "parallel" system, comprised of (4) SSPA modules. In the event of one module failure, a 'hitless' reduction of 3 dB output power is realized.

The SSPA is used with a separate 3RU power supply chassis. The power supply chassis is a redundant power supply comprised of three (3) power supply modules.

It is sized such that only two of the three modules are required to operate the amplifier system. The power supply modules are completely hot swappable. If a power supply module fails, it can be replaced via the front panel without taking the amplifier system off the air.

Alternate power supply options are available, in 1RU and dual 1RU configurations.



System Output Power Capacity

Due to the output waveguide and switches, there is always some residual loss in the output of phase combined HPA systems. This results in slightly less than the ideal 3dB power addition to the output power of a single HPA unit.

On 1:1 phase combined systems, the typical additive output power is 2.70 dB above the output power of a single HPA. On 1:2 phase combined systems, the typical additive output power is 2.50 dB above the output power of a single HPA.

For example, a 125W Ku-Band Compact Outdoor SSPA in a 1:1 phase combined system would have the following output power:

Single HPA: $P_{1dB} = 50.0$ dBm; $P_{sat} = 51.0$ dBm

1:1 phase combined system: $P_{1dB} = 52.7$ dBm; $P_{sat} = 53.7$ dBm



◀ **400W C-Band (4RU)
1:1 Phase Combined
System**



◀ **300W C-Band (3RU)
1:1 Phase Combined
System**

**2kW C-Band, 1:2 Phase
Combined SSPA System** ▶

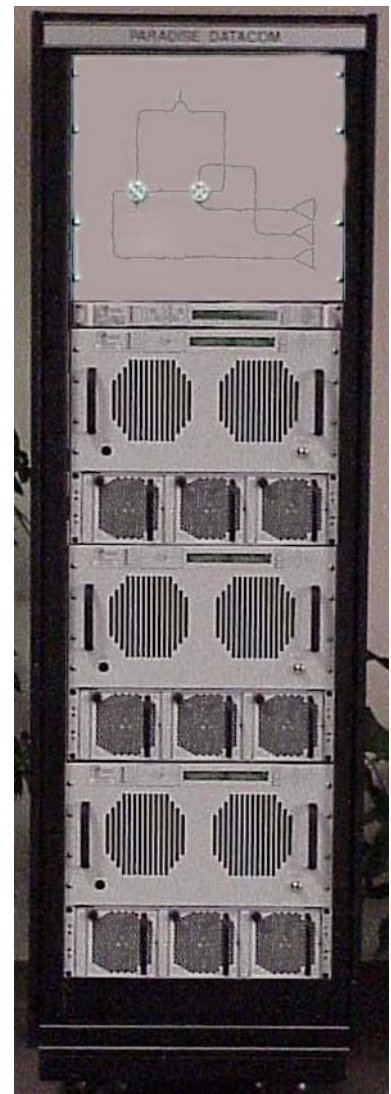



L-Band Operation

Paradise Datacom Phase Combined HPA Systems can be configured for L-Band Input operation. For optimum RF phase combining over the entire bandwidth of a communication amplifier, the frequency translation part of the system must be separated from the phase combining loop. Therefore, systems with L-Band input are configured with a separate 1:1 system of L-Band Block Up Converters that feed the 1:1 or 1:2 Phase Combined HPA system. If L-Band redundancy is not required, the system can be configured with a single thread L-Band Block Up Converter.

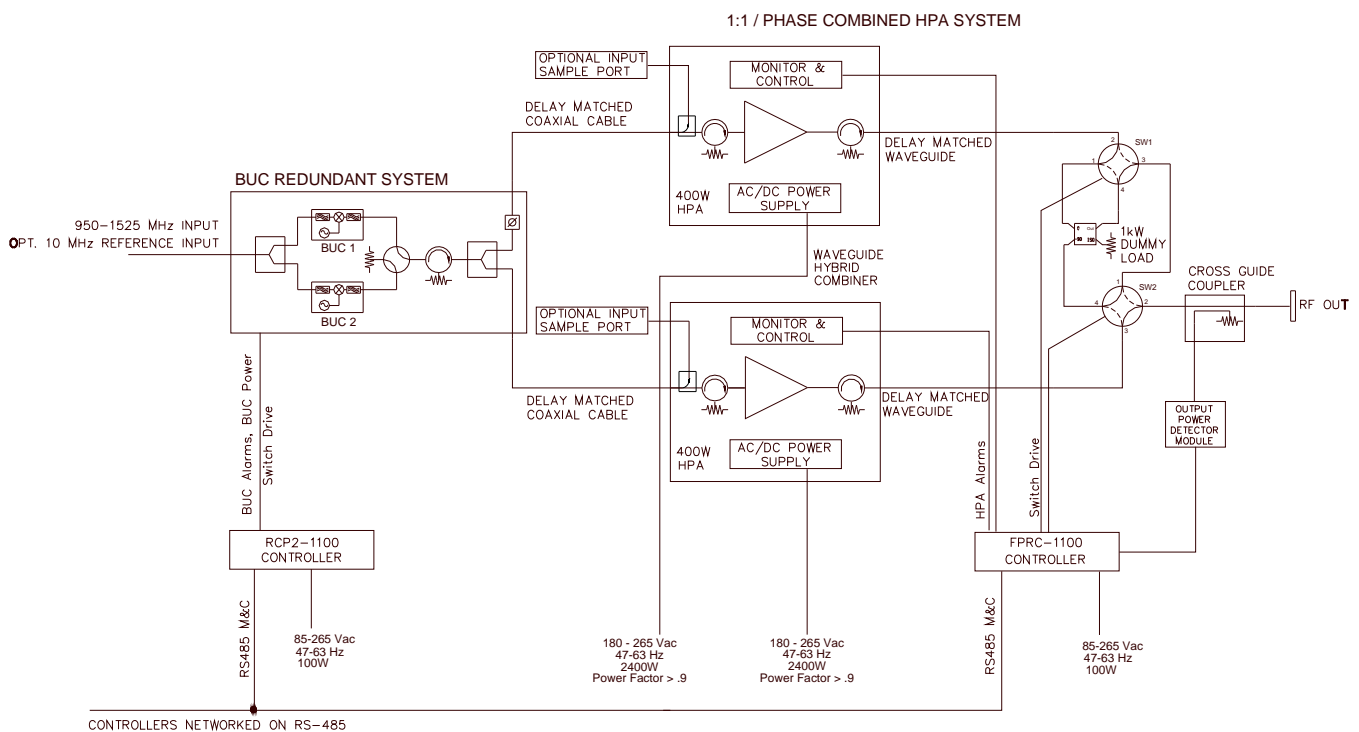

The Block Up Converter system is housed in a 1RU rack-mountable enclosure and controlled by a RCP2-1100 Redundant Controller. The Up Converters can be configured with internal reference oscillators or external reference oscillators. The Paradise Datacom ZBUC architecture allows a converter that is fitted with an internal reference oscillator to automatically detect and switch to an externally applied 10 MHz reference signal.

Optional input sample ports on each SSPA chassis are available on L-Band Input Phase Combined Systems to allow the user to monitor the output of the block up converter.



L-Band Operation

Paradise Datacom offers C-, X-, and Ku-Band amplifiers with an integrated L-Band Block Up Converter. The L-Band units utilize Paradise Datacom's proprietary ZBUC™ technology. The addition of a ZBUC™ to a Rack Mountable SSPA system typically increases the gain by 2-4 dB. The advantages of ZBUC™ technology include:

- ZBUC™ can detect and switch to an externally supplied reference.
- Optional internal high stability (10MHz) reference.
- ZBUC™ can lock to an externally supplied reference of 5, 10, 20, 25, or 50 MHz without modification.
- ZBUC™ can accept a wide range of external reference power (-10dBm to +5 dBm)
- ZBUC™ can accept FSK monitor and control signal via the IFL for complete amplifier remote control.

Available Frequency Plans

Band	Frequency Band	IF Input	LO Frequency	RF Output	Gain Change
C	Standard C-Band	950 - 1525 MHz	4.900 GHz	5.850 - 6.425 GHz	0-4 dB
C	Extended C-Band	950 - 1825 MHz	4.900 GHz	5.850 - 6.725 GHz	0-4 dB
C	Palapa Band	950 - 1250 MHz	5.475 GHz	6.425 - 6.725 GHz	0-4 dB
C	Insat Band	950 - 1250 MHz	5.775 GHz	6.725 - 7.025 GHz	0-4 dB
C	Extended C-Band 2	950 - 1675 MHz	4.800 GHz	5.750 - 6.475 GHz	0-4 dB
X	Standard X-Band	950 - 1450 MHz	6.950 GHz	7.900 - 8.400 GHz	0-2 dB
Ku	Standard Ku-Band	950 - 1450 MHz	13.050 GHz	14.00 - 14.50 GHz	0-2 dB
Ku	Extended Ku-Band	950 - 1700 MHz	12.800 GHz	13.75 - 14.50 GHz	0-2 dB

Electrical Specifications for RM SSPA System with ZBUC™

PARAMETER	NOTES	LIMITS				UNITS
Gain	Nominal setting	75				dB
Gain Flatness	full band (C-,X-,Ku-bands)	±2.0				dB
Gain Slope	per 40 MHz (C-,X-,Ku-bands)	±0.5				dB/40 MHz
Gain Adjusted Range		20				dB
	Typical C-Band Adj. Range	60 - 80				dB
	Typical Ku-Band Adj. Range	57 - 77				dB
Gain Stability	-40 to +60 °C	±1.5				dB
Phase Noise	Offset frequency from carrier	<u>Absolute max.</u>	<u>C-band (typ.)</u>	<u>X-band (typ.)</u>	<u>Ku-band (typ.)</u>	
	10 Hz	-30	-60	-60	-50	dBc/Hz
	100 Hz	-60	-80	-75	-65	dBc/Hz
	1 KHz	-70	-80	-75	-72	dBc/Hz
	10 KHz	-80	-85	-100	-90	dBc/Hz
	100 KHz	-90	-120	-110	-110	dBc/Hz
	1 MHz	-90	-125	-122	-120	dBc/Hz
Spurious	In-Band Signal Related (C-/Ku-Band) (Extended C-Band)	-50				dBc
		-40				dBc
	Close to Carrier Spurious (≤ 20 MHz) Local Oscillator	-50				dBc
	Non-Signal Related	-30				dBm
		-40				dBm
Noise Figure	At 75 dB gain setting	20				dB
Input VSWR	L-Band	1.5 : 1				
Internal Reference Option	Reference accuracy @ 25 °C	±1 • 10 ⁻⁸				
	Reference Stability over Temperature (-40 to +40 °C)	±1 • 10 ⁻⁹				



System Controllers

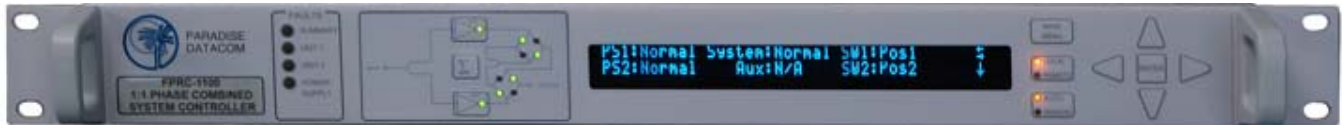

FPRC-1100 1:1 Phase Combined System Controller

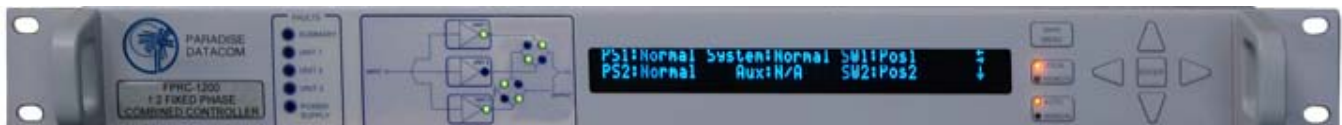

FPRC-1200 1:2 Phase Combined System Controller

The FPRC-1X00 is the heart of the Redundant SSPA System. It provides an extremely user friendly interface for complete monitor and control of the high power amplifiers. The front panel mimic display shows the on-line amplifiers and the switch positions. Fault lights are provided for easy indication of system status.

All FPRC-1X00 monitor and control is available locally at the front panel LCD display, as well as remotely by the RS232 , RS485, or Ethernet interface ports. Audible alarms and a full compliment of parallel I/O signal are available at the rear panel of the FPRC-1X00.

The FPRC-1X00 System Controller allows the Phase Combined System of amplifiers to be controlled as if it were a single SSPA. The FPRC is the single point of interface for either local, front panel, or remote control. System monitor and control capability include gain adjustment, output power monitoring (dBm or Watts), and alarms.

The FPRC-1X00 is a 1RU indoor control unit that contains its own internal redundant components including fully redundant power supplies.

Note: Systems can be configured without the use of a system controller. Consult the factory for operation of phase combined systems without a system controller.



General System Specifications

PARAMETER	NOTES	LIMITS	UNITS
Gain	minimum minimum (units with L-Band input)	70 67	dB dB
Gain Flatness	full band (All except Extended C-Band) Extended C-Band units	±1.0 ±1.5	dB dB
Gain Slope	per 40 MHz	±0.3	dB/40 MHz
Gain Variation vs. Temperature	0°C to +50°C	±1.0	dB
Gain Adjustment	0.1 dB resolution	20	dB
Intermodulation Distortion	3dB back off relative to P _{1dB}	-25	dBc
AM/PM Conversion	(@ rated P _{1dB}) (@P _{1dB} -3dB)	3.5 0.5	°/dB °/dB
Spurious Harmonics	(@ rated P _{1dB}) (@ rated P _{1dB} -3dB)	-60 -50	dBc dBc
Input/Output VSWR	All units except Extended C-Band Extended C-Band	1.30:1 1.50:1	
Noise Figure	at maximum gain	12	dB
Group Delay (per 40 MHz segment)	Linear Parabolic Ripple	0.01 0.003 1.0	ns/MHz ns/MHz ² ns p-p
Noise Output	TX Band (4 RU / 6 RU) RX Band (4 RU / 6 RU)	-75 / -70 - 150 / -155	dBW/4 KHz dBW/4 KHz
Residual AM Noise	0 - 10 KHz 10 KHz - 500 KHz 500 KHz - 1 MHz	-45 -20 (1.25 + log F) -80	dBc dBc dBc
Phase Noise		IESS -308/309 - 10 dB	

Mechanical

Size 3 RU HPA Chassis	width X height X depth	19.0 X 5.22 X 24.13 483 X 133 X 613	inches mm
Size 4 RU HPA Chassis	width X height X depth	19.0 X 7.0 X 28.0 483 X 178 X 711	inches mm
Size 6 RU HPA Chassis	width X height X depth	19.0 X 10.47 X 30.0 483 X 266 X 762	inches mm
Size Power Supply Chassis	width X height X depth	19.0 X 5.25 X 15.44 483 X 134 X 433	inches mm
Weight 3 RU HPA Chassis 4 RU HPA Chassis 4 RU HPA Chassis 6 RU HPA Chassis Power Supply Chassis	≤ 250W Chassis > 250W Chassis	66 (30) 75 (34) 100 (45) 180 (82) 50 (23)	lbs.(kg) lbs.(kg) lbs.(kg) lbs.(kg) lbs.(kg)
Finish		powder coat	Gray

Environmental

Operating Temperature	Ambient	0 to +50	°C
Relative Humidity	Condensing	95	%
Cooling System	Integrated	Forced air	

Specifications are subject to change.

