



Compact Outdoor SSPA with External Fiber-Optic Interface (OFM-1000)

DESCRIPTION

Paradise Datacom offers a robust fiber-optic interface solution for the popular Compact Outdoor Solid-State Power Amplifier and Evolution Series Modems. The interface allows protocol transparent transmission of block down-converted C-, X-, and Ku-Band signals for distances of up to 10 km.

Full asymmetric up/downlink is provided to the Compact Outdoor SSPA using our fiber optic transceiver system consisting of a low-cost 1RU RCPF-1000 Remote Control Panel and the OFM-1000 outdoor fiber module. Paradise Datacom's Universal M&C software allows full control of the unit over the fiber connection.

Optional mounting kits are available for both the Compact Outdoor SSPA and the OFM-1000 to secure the equipment to the antenna boom.

FEATURES

- System Output Power to:
300W C-Band;
250W X-Band;
125W Ku-Band
- Internal or External Reference Block Up Converter
- Indoor Remote Control Panel

OPTIONS

- 110 VAC Input Power
- BUC Bypass Switch
- Side-mount Power Input for SNG applications
- 1:1 Redundant Tx Systems
- 1:1 Dual Redundant Tx & Rx Systems



L-Band to Fiber RF Characteristics

Parameter	Limits
Frequency Range	950-1525 MHz (Standard C-Band) 950-1825 MHz (Extended C-Band 1) 950-1250 MHz (Insat, Palapa) 950-1675 MHz (Extended C-Band 2) 950-1450 MHz (Standard X-Band) 950-1450 MHz (Standard Ku-Band) 950-1700 MHz (Extended Ku-Band)
Flatness	± 1.5 dB max (Standard bands) ± 2.0 dB max (Extended bands)
Gain Slope	.25 dB over any 6MHz
Return Loss	-12 dB max.
Intermod. Products	-25 dBc (at amplifier output)
CNR	70 dB @ 36MHz / 1km
Input Signal (Nominal Composite)	0dBm
Maximum Input Power	+10dBm (without damage)
Gain Stability	.25 dB @24 hours
Link Gain	0 ± 3 dB w/ 2m fiber
OIP3, 2-tone	+10dBm
Noise Figure (typical)	30dB
SFDR	100 dBm/Hz
Output Reference Level	> 0 dBm
LNB Bias	15 VDC @ 500mA max.

Optical Characteristics

Parameter	Limits
Optical Wavelength	1310nm, 1550nm with internal WDM
Optical Power Output	0dBm Nominal
Optical Connector	Indoor: SC/UPC Outdoor: PT/LC (Amphenol # 956-220-5000-R)
Optical Budget	2.5 dB, Fiber + Connectors

RCPF-1000 Remote Control Panel

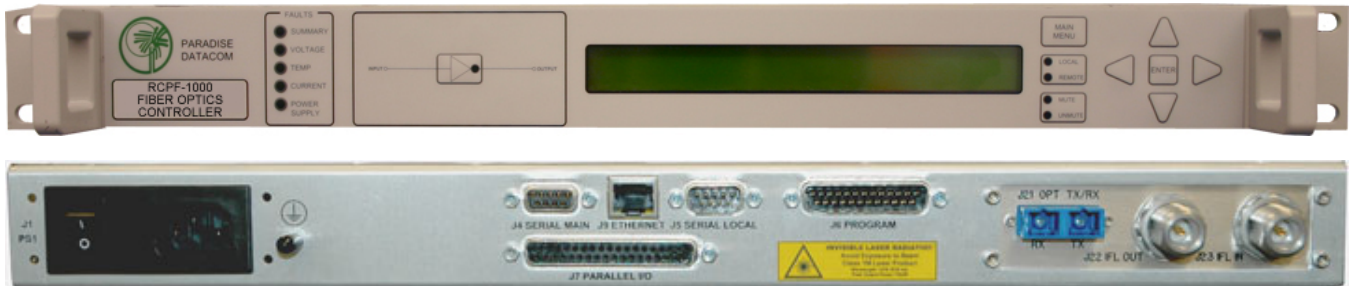

The RCPF-1000 Fiber Optic Controller provides easy remote monitor and control of the Compact Outdoor SSPA with the OFM-1000 outdoor fiber-optic transceiver. Control of the RCPF-1000 can be handled through front panel operation or remotely via parallel or serial communication to a remote computer running Paradise Datacom's Universal M&C software.

The RCPF-1000 front panel includes 10 LEDs that indicate the internal state of the Compact Outdoor SSPA. Five fault condition LEDs on the left side of the front panel indicate any SSPA major faults, in addition to a summary fault state. A 2 line by 40 character LCD provides an extremely user friendly interface. Virtually all of the controller's setup and adjustments are accessible from the LCD. Four navigation buttons and a separate Enter key allow the user to navigate the firmware menu on the LCD.

Separate buttons have been provided for frequently used functions. A range of RF hardware options is offered to meet specific system requirements.

External Interface for Compact Outdoor SSPA OFM-1000 (Outdoor Fiber Module)

The External L-Band to Fiber Interface (OFM-1000) is a machined aluminum watertight enclosure, with N-type connectors for L-Band RX and TX. The optical connector is an Amphenol PTLC that is qualified for harsh environmental conditions. The enclosure is powered via a +15 VDC Input port from the Compact Outdoor amplifier. The amplifier also provides monitored LNB bias plus an alarm from the fiber system.

The OFM-1000 external interface allows connection between Paradise Datacom's Compact Outdoor amplifier with integrated ZBUC Block Up Converter and a 1RU indoor RCPF-1000 Fiber Optic Controller.

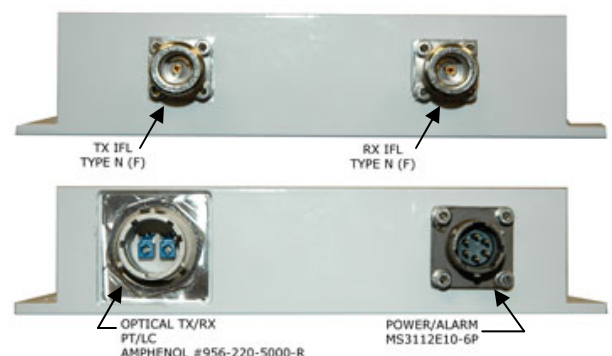

**Input / Output view
of External Fiber-Optic Interface**

Block Diagram: Fiber System with OFM-1000 interface to Compact Outdoor SSPA

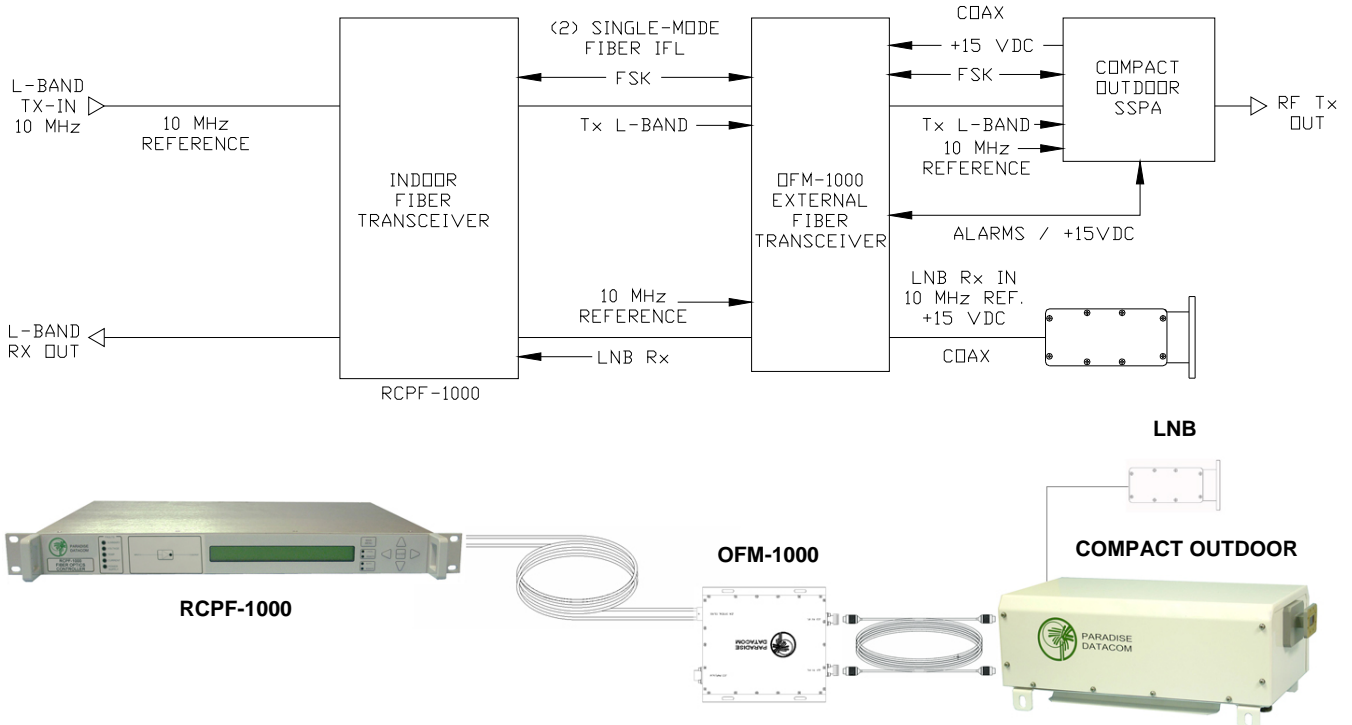

Outline Drawing: Optional Antenna Boom Mounting Bracket for OFM-1000

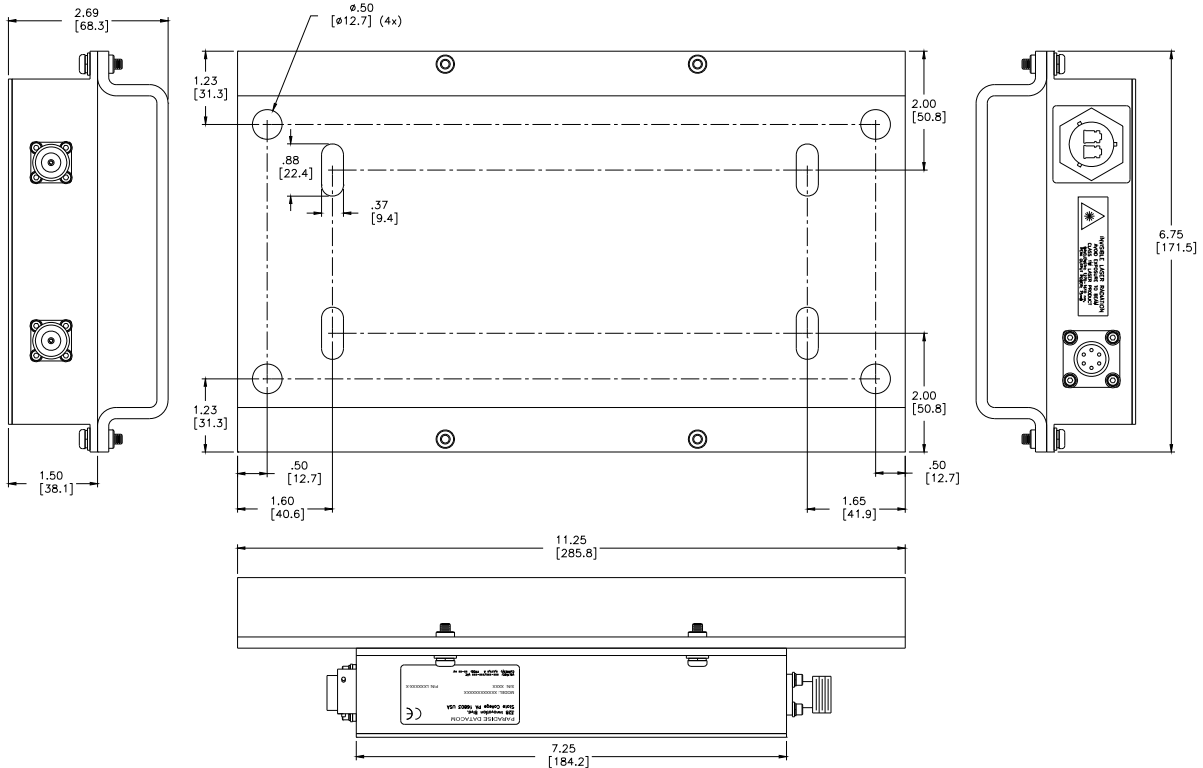

Dual Redundant Fiber Systems

Two fiber optic systems can be arranged as a dual redundant system, allowing redundancy in both the receive and transmit paths. Each Compact Outdoor Amplifier has a built-in 1:1 redundant controller, which is activated via computer command from the Paradise Datacom Universal M&C application.

A link cable connected between the two amplifiers passes command and control signals, and a switch cable connects between each amplifier and the redundancy switch(es). The internal controller for either amplifier will engage the switch(es) to route the output through a non-faulted amplifier to the RF output.

