



## OVERVIEW

The low cost **QUANTUM Series PD20** brings the *bandwidth saving* and *robustness* benefits of **DVB-S2** to traditional SCPC services such as IBS and Drop & Insert. In addition, **Paired Carrier** technology overlays transmit and receive carriers reducing satellite bandwidth by up to 50%. Paired Carrier™ technology is patented by Viasat Inc.

QUANTUM modems are fully backward compatible with Paradise Evolution modems when DVB-S2 and Paired Carrier are disabled.

## SCPC features, DVB-S2 Space Segment

Modes of operation:

- ▶ DVB-S2 outbound with SCPC return, or SCPC outbound with DVB-S2 return.
- ▶ DVB-S2 outbound and return.
- ▶ SCPC outbound and return.
- ▶ SmartLink mode where Tx/Rx SCPC features are combined with DVB-S2 space segment savings. All traditional SCPC features are supported including IBS, IDR, ESC, Drop & Insert, AUPC, etc.

## FEATURES

- ▶ Data rate options to 20Mbps, 10Msymbol/s maximum.
- ▶ All the standard features and options of the Evolution Series Modem including IBS, IDR, Drop & Insert, etc.
- ▶ DVB-S2 FEC and modulation support.
- ▶ Paired Carrier ready. Requires just an upgrade.
- ▶ Ethernet plus a further 3 x traffic interfaces supporting a wide range of terrestrial interfaces.
- ▶ Supports up to two Quad E1 cards allowing up to 8 x E1s to be multiplexed onto a single carrier
- ▶ Available in IF, L-band, and IF plus L-band.

## Paired Carrier Operation

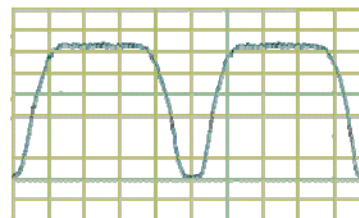

Paired Carrier Disabled

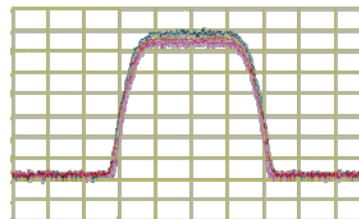

Paired Carrier Enabled  
Can save 50% on space segment

Common Main Specifications	
Parameter	QUANTUM Series Modem
Modulation Scheme	SCPC: BPSK, QPSK, OQPSK plus options: 8PSK, 16QAM, FastLink 8QAM, FastLink 16APSK, FastLink 32APSK, FastLink 64QAM DVB-S2 (Option): QPSK, 8PSK, 16APSK
IF Frequency Range	50 - 90MHz & 100 - 180MHz
IF Frequency Resolution	100Hz
Traffic Interface - Electrical	Ethernet (10/100 BaseT) IP Traffic on RJ45 with link and traffic indicators. Electronically selectable with other interfaces fitted.
Traffic Interface - Options	RS422 including X.21 DCE and DTE emulation, V.35 and RS232 on EIA530 connector 25 pin female D-type (Option), EIA530 maximum 10Mbps, RS232 max 100kbps Serial LVDS 25 pin female D-type (Option) HSSI 50 pin HD SCSI-2 connector (Option) G.703 balanced on EIA530 G.703 unbalanced on BNC female 75Ω Quad E1 G.703 balanced on RJ45 IP Traffic card 10/100/1000 BaseT on RJ45 Eurocom D/1 on 25 pin male D-type includes: Eurocom D <16kbps to >2,048kbps AMI coded Eurocom C 256kbps, 512kbps, 1,024kbps and 2,048kbps HDB3 coded, plus Eurocom G 16kbps or 32kbps diphase coded MultiMux feature allows a mix of multiple G.703 interfaces plus IP and/or EIA530 traffic with a limit of 2,048kbps per MultiMux traffic port (4 x ports max)
User Traffic Data Rate	SCPC: 4.8kbps - 2,048kbps in base Modem DVB-S2 50kbps - 2,048kbps in base Modem, subject to minimum symbol rate of 100ksymbol/s Extension of base operation to 5Mbps (Option) Extension of 5Mbps to 10Mbps (Option) Extension of 10Mbps to 20Mbps (Option) Extensions are cumulative
User Traffic Data Rate Resolution	1bps
<b>Note:</b> The combination of FEC Rate, Modulation scheme and Satellite Overhead limits the Traffic Data Rate Range in all modes.	
User Data Rate Range - Closed Network	4.8kbps to 20Mbps no Satellite Overhead (with high Data Rate options)
User Data Rate Range - Minimum Overhead (Closed Network plus ESC)	As Closed Network above except limits inclusive of overhead of approximately 1.4 times the ESC baud rate. Resolution of 1bps. Supports ESC rate from 110 baud to >38.4kbaud.
User Data Rate Range - IBS/SMS Option	4.8kbps to 10 Mbps (6.7% Satellite Overhead added). Resolution of 1bps.
User Data Rate Range - IDR Option	4.8kbps to 10 Mbps (96k overhead added) Resolution of 8k (limitation of frame structure)
Audio Channels Option (P1348 emulation mode)	Used with IBS/SMS satellite framing and IDR Options to provide 2 x audio 32kbps ADPCM coded channels within a 64kbps IBS carrier, and 2 x audio 32kbps ADPCM coded channels plus 64kbps data within a 128kbps IBS carrier
Inner Forward Error Correction	Viterbi BPSK/QPSK/OQPSK - Rates 1/2, 3/4, 7/8, k=7 to IESS-308/309 Option: Sequential BPSK/QPSK/OQPSK - Rates 1/2, 3/4, 7/8 up to 2,048kbps maximum Option: TCM 8PSK - Rate 2/3 to IESS-310 Option: TPC BPSK - Rates 5/16, 21/44, 0.493 (Paradise), 2/3, 3/4, 0.789 (Paradise), 7/8 (Paradise), Rate 7/8 de facto Option: TPC QPSK/OQPSK - Rates 5/16, 21/44, 0.493 (Paradise), 2/3, 3/4, 0.789 (Paradise), 7/8 (Paradise), Rate 7/8 de facto, Rate 0.93 (Paradise) Option: TPC 16QAM - Rates 3/4 de facto, 7/8 de facto, Rate 0.93 (Paradise) Option: FastLink Low-Latency LDPC. Combines low latency and excellent BER performance, providing a practical single-FEC alternative to both TPC and conventional LDPC. Supports BPSK, QPSK, 8PSK, 8QAM, 16APSK, 16QAM, 32APSK and 64QAM.
Outer Forward Error Correction	Concatenated Intelsat Reed-Solomon Outer Codec to IESS308/310 with Custom Option offering variable code rate. Maximum traffic rate 10Mbps.
Scrambling - IBS/SMS Option	Synchronised to framing per IESS-309 up to 10 Mbps
Scrambling - IDR Option and Closed Network	With RS Coding: synchronised to RS overhead. Without RS Coding and Non-TPC FEC: V.35 self-synchronising No RS Coding with TPC FEC: 2 <sup>n</sup> *12-1 up to 10 Mbps
Scrambling - SCPC Closed Network Plus ESC	32kbps or above: synchronised to ESC overhead. Less than 32kbps: as per closed network. V.35 Scrambler has CCITT, Intelsat, "FDC" and "Linkabit" modes up to 20Mbps (with high Data Rate options)
Scrambling - DVB-S2	As per ETSI EN 302307
IF Connector type	BNC female
IF Impedance	50Ω & 75Ω, electronically selectable
Return Loss	18dB typical
Internal Frequency Reference - Ageing	<1ppm/yr
External Reference	Clocking Only: 1-10MHz in 1kHz steps. Clocking and RF Frequency: 10MHz, 0dBm±1dB

Modulator Specifications	
Parameter	QUANTUM Series Modem
Output Power Level	0 to -25dBm Continuously Variable in 0.1dB steps
Output Level Stability	±0.5dB, 0°C to 40°C
Transmit Filtering Selectable	Intelsat IESS and DVB-S2 compliant α = 0.35      α = 0.25      α = 0.20
Occupied Bandwidth	1.2 x Symbol Rate      1.13 x SR      1.1 x SR
Recommended Channel Spacing	1.4 x Symbol Rate      1.27 x SR      1.2 x SR
Phase Accuracy	±2° maximum
Amplitude Accuracy	±0.2dB maximum
Carrier Suppression	-30dBc minimum
Output Phase Noise	As IESS-308, nominally 3dB better.
Output Frequency Stability	<1ppm/yr
Harmonics	Better than -55dBc/4kHz in band
Spurious	Better than -55dBc/4kHz in band
Transmit On/Off Ratio	55dB minimum
External Transmit Inhibit	By external contact closure or by TTL signal applied to rear panel Alarms & AGC connector
Adaptive Signal Predistorter	Option: Use with 16QAM to relax HPA backoff by up to 1.6dB. Compensates for HPA non-linearities.

BER Performance - Guaranteed dB (Typical)						
SCPC mode	Rate 1/2	Rate 3/4	Rate 7/8	Rate 2/3	Rate 0.93	
Viterbi QPSK	1E-4	4.7 (4.4)	6.1 (5.8)	7.1 (6.8)		
	1E-8	7.2 (6.9)	8.8 (8.5)	9.5 (9.2)		
Sequential (64kbps)	1E-4	4.3 (4.0)	5.4 (5.1)	6.4 (6.1)		
	1E-8	6.4 (6.1)	7.3 (7.0)	8.6 (8.3)		
Sequential (2048kbps)	1E-4	5.6 (5.3)	6.1 (5.8)	6.9 (6.6)		
	1E-8	7.5 (7.2)	8.1 (7.8)	8.4 (8.1)		
Turbo (TPC) QPSK	1E-4	2.7 (2.4)	3.5 (3.2)	4.1 (3.8)		
	1E-6					6.3 (6.0)
Turbo (TPC) 8PSK	1E-8	3.3 (3.0)	4.5 (4.2)	4.5 (4.2)		6.8 (6.5)
	1E-4		5.6 (5.3)	6.8 (6.5)		
Turbo (TPC) 16QAM	1E-6					10.0 (9.7)
	1E-8		7.8 (7.5)	8.2 (7.8)		10.7 (10.4)
8PSK/TCM	1E-3		6.5 (6.2)	7.7 (7.4)		
	1E-6					6.3 (6.0)
8PSK/TCM + Reed-Solomon (all rates)	1E-8					10.4 (10.1)
	1E-4					6.1 (5.8)
	1E-10					7.3 (7.0)

**FASTLINK LOW-LATENCY LDPC BER PERFORMANCE: SEE SEPARATE FASTLINK DATASHEET**

Demodulator Specifications	
Parameter	QUANTUM Series Modem
Input Range	-30 to -60dBm wanted signal
Maximum Composite Signal	30dB above level of desired input up to a maximum of 0dBm
Frequency Acquisition Range	Selectable from ±1kHz to ±32kHz up to 10 Msps (1kHz steps) ±10kHz to ±250kHz above 10 Msps (10kHz steps)
Acquisition Threshold	<5dB Es/No QPSK
Acquisition Time	At 9.6kbps, less than 1s at 6dB Es/No QPSK At 10 Mbps, less than 100ms at 6dB Es/No QPSK
Clock Tracking Range	±100ppm minimum
Receive Filtering Selectable	Intelsat IESS compliant α = 0.35, α = 0.25, α = 0.20
Performance Monitoring	Measured Eb/No (range 0-15dB, ±0.2dB). Measured Frequency Offset (100Hz resolution). Wanted signal level strength indicator centred on the middle of the Rx Input range.
AGC Output	Buffered direct AGC output for antenna tracking, etc.

Data Rate Specifications			
Modulation/FEC	FEC Rate de facto	Min Data Rate (kbps)	Max Data Rate (Mbps)
BPSK VIT / SEQ	1/2	4.8	5 / 2
BPSK VIT / SEQ	3/4	7.2	7.5 / 2
BPSK VIT / SEQ	7/8	8.4	8.7 / 2
BPSK VIT RS	1/2	4.3	4.4
BPSK VIT RS	3/4	6.4	6.6
BPSK VIT RS	7/8	7.5	7.7
O/QPSK VIT / SEQ	1/2	9.6	10 / 2
O/QPSK VIT / SEQ	3/4	14.4	15 / 2
O/QPSK VIT / SEQ	7/8	16.8	17.5 / 2
O/QPSK VIT RS	1/2	8.6	8.8
O/QPSK VIT RS	3/4	12.8	13.3
O/QPSK VIT RS	7/8	15	15.5
O/QPSK TPC	1/2	9.6	10
O/QPSK TPC	3/4	14.4	15
O/QPSK TPC	7/8	16.8	17.5
O/QPSK TPC	0.93	17.9	18.6
8PSK TCM	2/3	19.2	20
8PSK TCM RS	2/3	17.7	18.3
8PSK TPC	3/4	21.6	20
8PSK TPC	7/8	25.2	20
8PSK TPC	0.93	26.8	20
16QAM TPC	3/4	28.8	20
16QAM TPC	7/8	33.6	20
16QAM TPC	0.93	35.8	20
DVB-S2 QPSK	1/4	50	4.9
DVB-S2 QPSK	1/3	65.7	6.5
DVB-S2 QPSK	2/5	79	7.8
DVB-S2 QPSK	1/2	98.9	9.8
DVB-S2 QPSK	3/5	118.9	11.8
DVB-S2 QPSK	2/3	132.3	13.2
DVB-S2 QPSK	3/4	148.8	14.8
DVB-S2 QPSK	4/5	158.8	15.8
DVB-S2 QPSK	5/6	165.5	16.5
DVB-S2 QPSK	8/9	176.7	17.6
DVB-S2 QPSK	9/10	178.9	17.8
DVB-S2 8PSK	3/5	178	17.7
DVB-S2 8PSK	2/3	198.1	19.8
DVB-S2 8PSK	3/4	222.9	20
DVB-S2 8PSK	5/6	247.9	20
DVB-S2 8PSK	8/9	264.7	20
DVB-S2 8PSK	9/10	268	20
DVB-S2 16APSK	2/3	263.8	20
DVB-S2 16APSK	3/4	296.7	20
DVB-S2 16APSK	4/5	316.6	20
DVB-S2 16APSK	5/6	330.1	20
DVB-S2 16APSK	8/9	352.4	20
DVB-S2 16APSK	9/10	356.8	20

**FASTLINK LOW-LATENCY LDPC MODCODS: SEE SEPARATE FASTLINK DATASHEET**

BER Performance - Guaranteed dB (Typical)												
DVB-S2 mode	Rate 1/4	Rate 1/3	Rate 2/5	Rate 1/2	Rate 3/5	Rate 2/3	Rate 3/4	Rate 4/5	Rate 5/6	Rate 8/9	Rate 9/10	
QPSK	5E-8	1.45 (1.1)	1.68 (1.33)	1.48 (1.13)	1.80 (1.45)	2.30 (1.95)	2.44 (2.09)	2.83 (2.48)	3.24 (2.89)	3.56 (3.21)	4.18 (3.83)	4.32 (3.97)
8PSK	5E-8				4.45 (4.10)	4.45 (3.83)	4.97 (4.62)		6.01 (5.66)	7.12 (6.77)	7.47 (7.12)	
16APSK	5E-8					5.94 (5.59)	6.53 (6.18)	7.25 (6.90)	7.16 (6.81)	8.48 (8.13)	8.93 (8.58)	

Framing and Deframing Specifications	
Parameter	QUANTUM Series Modem
Closed Network Format	Unframed, no overhead.
IBS/SMS Option Format	Intelsat IBS to IESS-309 and IESS-310 up to 10 Mbps, and Eutelsat SMS to EESS-501.
IDR Option Format	Intelsat IDR to IESS-308 and IESS-310 up to 10 Mbps.
Closed Network plus ESC Format	Provides variable rate asynchronous ESC, optional synchronous scrambler above 32kbps to replace error multiplying V.35 scrambler, optional backward alarm facility and optional timeslot ID maintenance when used with Drop/Insert, all in minimum possible overhead down to <0.5%
Format of Other Modes	For custom options, see handbook.
Poor BER Performance	Deframer includes extended threshold operation that improves performance when used with Reed-Solomon in very poor BER conditions (where a single uncorrectable RS codeword can contain enough corrupt frame alignment words to knock an Intelsat scripted deframer out of frame sync). Up to 10 Mbps.

Drop & Insert Option Specifications	
Parameter	QUANTUM Series Modem
Bearer Types	T1-D4, T1-ESF and E1-G.732
Timeslot Selection	Independent selection of arbitrary timeslots for both drop and insert.
Bearer Generation	The terrestrial bearer may be looped through the Drop Mux then Insert Mux, or terminated after the drop Mux and a new blank bearer generated by the insert Mux. The bearer generated within Insert Mux provides full multiframe and CRC support and may be generated from the Tx clock, station reference, satellite clock or internal reference.
Bearer Backup	In the event that Insert Mux bearer clock is lost, or AIS is supplied, then Insert Mux will switch temporarily to bearer generation mode in order to preserve receive traffic. The backup bearer may be generated from the station reference, satellite clock or internal reference.
Terrestrial CRC	Fully supported, with front panel display of terrestrial error rate based on CRC (T1-ESF and G.732) or Frame Alignment Word errors (all bearer types).
Timeslot ID	The IBS/SMS or Closed Net Plus ESC overhead maintains the identity of individual Drop/Insert timeslots for N=1,2,3,4,5,6,8,10,12,15,16,20,24 and 30. (See extended option below).

Advanced ESC and Advanced Aux Option Specifications		
Parameter	QUANTUM Series Modem	
ESC/Aux Port	A single port provides the interface for optional high rate async ESC (IBS/SMS option or Closed Net Plus ESC) or the Intelsat low rate async IBS ESC channel.	
Electrical Interface	RS232, RS422 or RS485 external interfaces or internal link to remote M&C port (software selected). Other devices externally wired in parallel with M&C port can also be accessed remotely.	
Async ESC Option	Closed Net Plus ESC	Overhead scales to provide any user specified async ESC baud rate whatever the satellite data rate. ESC limit is approximately 70% of main channel rate, overhead varies from <0.5% to >70%.
	IBS Option	High rate async data using from 1/32nd to 22/32nd of the IBS overhead, providing async baud rates from 0.2% to 5.1% of the terrestrial rate (e.g., up to >2400 baud at 64kbps). Includes modes compatible with the P300 and P400 Series, P230 & P1300/P1361 (using 20/32nd of the overhead).
IBS Aux Data Channel	With IBS option and Advanced Aux option: Intelsat low rate async ESC definition carried in bit 1 of TS32 providing a synchronous channel at 1/480th of the data rate, allowing up to one quarter of this rate for over-sampled async data. Compliant with Intelsat IESS-403 low rate ESC definition.	

Clocking and Buffering Specifications		
Parameter	QUANTUM Series Modem	
Clock Integrity	Frequency Locked Loops give phase-hit immune operation even with poor clock sources such as routers etc.	
Tx Clocking SCPC mode	Internal	Standard ( $\pm 1$ ppm)
	External	Tracking range $\pm 100$ ppm/min
Rx Clocking SCPC mode	Rx Clock	Slaves Tx timing from Rx clock. (Includes full asymmetric operation)
	Buffer Disable	Clock from Satellite
	Tx Input clock	Plesiochronous. (Includes full asymmetric operation)
	Internal	Standard $\pm 1$ ppm
	External timing clock (DTE interface only)	
	Station Reference (see below)	
Tx Clocking DVB-S2 mode	Internal	Free-running (tied to symbol rate)
	External	Tracking range $\pm 100$ ppm/min
Rx Clocking DVB-S2 mode	Buffer Disable	Clock from Satellite
Station Reference Inputs	75 $\Omega$ BNC female Station Clock Connector, transformer isolated, 1MHz to 10MHz in 1kHz steps (accepts sinusoidal >0dBm or square-wave e.g. G.703 para 10)	
	120 $\Omega$ RS422 compatible input, 1MHz to 10MHz in 1kHz steps via Async ESC connector	
	NB: When set to 10MHz, the station reference may replace internal reference to all internal circuitry. Unit automatically switches back to internal reference if station reference fails.	
Buffer Size	Selectable in 1ms increments from 0ms to 99ms. Automatically adjusted to slip an integer number of terrestrial multi-frame lengths for framed rates. Buffer storage: Maximum buffer size – 256kbytes.	

Extended Drop & Insert Option Specifications	
Parameter	QUANTUM Series Modem
Timeslot Re-Ordering	Selected timeslots may be independently re-ordered on both Tx and Rx paths.
Multi-Destination Working	All or only a subset of the received data may be inserted into the terrestrial bearer on the receive path for multi-destinational working.
Timeslot ID Maintenance	The IBS/SMS or Closed Net Plus ESC is extended to maintain the identity of individual timeslots for all values of N from 1 to 31.
Signalling	Both Channel Associated Signalling (CAS) and Robbed Bit Signalling (RBS) are fully supported. For G.732 Drop/Insert, CAS signalling is extracted from terrestrial TS16 and carried over the satellite in IBS/SMS TS16 and TS48 before re-inserting into the distant terrestrial TS16. For RBS, the IBS or Closed Net Plus ESC overheads maintain the identity of the in-band signalling and it is re-inserted into the terrestrial multi-frame in the correct positions to maintain the RBS.

Paired Carrier	
Parameter	QUANTUM Series Modem
Paired Carrier	Transmit and receive carriers are overlaid on top of each other in the same space segment. Echo cancellation techniques are used in the demodulator to cancel the transmit carrier and extract the wanted receive carrier signal.
Paired Carrier data rate options	512kbps, 1024kbps, 2.5Mbps, 5Mbps, 10Mbps, 15Mbps and 20Mbps traffic rate

Intelsat Reed-Solomon Codec & Custom Option Specifications	
Parameter	QUANTUM Series Modem
Maximum traffic rate	10Mbps
Format	Concatenated Reed-Solomon outer codec to IESS-308/310.
Code Rate	Default n, k, t = (126, 112, 7) depth 4. Automatically switches to: (225, 205, 10) depth 4 for 1544kbps IDR mode or (219, 201, 9) depth 4 for 2048kbps IDR mode and TCM<=1544kbps or (219, 201, 9) depth 8 for TCM >1544kbps.
Processing Delay (bits)	Combined encoder and decoder: 8 x (2n-k+60) Combined Interleaver/De-Interleaver: 8 x n x Depth Calculate delay time using data rate including RS overhead.
Custom Option	When fitted allows arbitrary selection of n and k to provide fully variable code rate. 60<=n<=255, (n-20)<=k<=(n-2) in steps of 2. Interleaver depth of 4 or 8. The custom option allows use of shorter code words to reduce interleaver/de-interleaver delay on low data rate circuits.

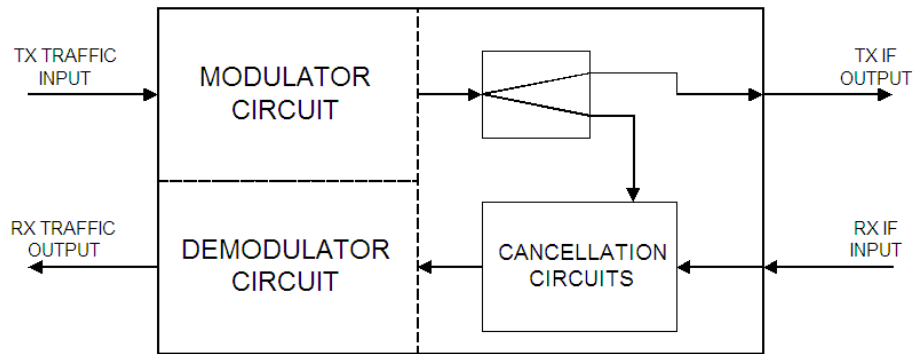

### PAIRED CARRIER MODEM SCHEMATIC

Paired Carrier technology allows both the uplink and downlink signals to occupy the same space segment. An adaptive self-interference cancellation technique removes the uplink signal components generated by the local terminal from the received signal off satellite, allowing demodulation of the far end signal.

Ethernet Traffic	
Parameter	QUANTUM Series Modem
Throughput Performance	The maximum modem throughput depends on IP traffic format and the features enabled. Bridged IP/UDP data can be processed up to the maximum data rate of the modem. Please seek assistance from Paradise Datacom in evaluating your particular requirements.
Routing and Bridging	Bridging (standard). Basic routing with static routes (standard). Dynamic routing option: RIP V1 and V2; OSPF V2 and V3; BGP V4.
TCP Acceleration	Typical throughput level of 90% of link capacity. 5,000 concurrent accelerated TCP connection limit. If running on base modem then TCP acceleration is limited to a maximum of 10Mbps; with the P3714 IP Traffic card option, TCP acceleration will run to the maximum data rate for the modem. If used with an IP Traffic card then includes HTTP Acceleration (prefetches web page inline objects to reduce web page download times).
Header Compression	Requires P3714 IP Traffic card option (other than for Ethernet header compression, which can also run on the base modem). Robust Header Compression to RFC 3095 profile 2 (IP/UDP). Reduces Ethernet/IP/UDP header sizes typically by 90%. 1-way packet processing limit: 58,000 pps; 2-way limit: 44,000 pps. Also includes Ethernet header compression (compresses 14-byte Ethernet frame to typically one byte).
Traffic Shaping	Provides guaranteed throughput levels for specific IP streams, using standard Committed Information Rate and Burst Information Rate settings. Stream differentiation is by IP address, IEEE 802.1p priority class, Diffserv DSCP class or MPLS EXP field.
VLAN Support	IEEE 802.1q VLAN support (standard). IEEE 802.1p Quality of Service (packet prioritisation) using strict priority or fair weighting queuing.
IP over DVB Encapsulation/Decapsulation	Requires P3714 IP Traffic card option. Supports MPE, ULE and Paradise PXE. Includes MPE air MAC address filtering.
DVB-S2 IP Multistreaming	Requires P3714 IP Traffic card option. Point-to-multipoint CCM and VCM multistreaming. VCM allows the FEC error correction to vary for each remote.
DVB-S2 ACM	Dynamically varies point-to-point FEC strength and throughput, maximising throughput for the actual link conditions.
DHCP, SNMP	DHCP (standard) for automatic allocation of M&C IP address. SNMP (standard) v1, v2c and v3.
Web Server	Standard. Embedded web server (standard) M&C interface.
IP Diagnostic Graphs	Standard. Shows throughput (bps, pps); dropped, errored packet counts.
Operating mode	Can be operated in stand-alone, 1:1 or 1:N redundancy configuration.

Traffic Log Specifications	
Parameter	QUANTUM Series Modem
Capacity	Over 6000 entries
Entry Format	Fault message with time and date stamp. Separate entry when fault clears/changes.

Unique Web User Interface provides full Monitor & Control plus graphing of Eb/No, BER, Receive Power and other operating parameters, plus a Receive Spectrum Analyser, Receive Constellation Monitor and BER Tester for detailed signal analysis and performance validation via Internet Explorer. Logged graph data can be sent via email to any email address.

*Built-in Spectrum Analyser for Receive Carrier, Adjacent Carrier and Super-Wide Monitoring*

*Built-in Receive Constellation Display for channel diagnostics.*

IDR Option Specifications	
Parameter	QUANTUM Series Modem
IDR ESC Audio Interface	Two 32kbps ADPCM channels
Backward Alarms	Outputs: Four "form C" relays. Inputs: Four protected inputs, short to 0V to send alarm with matching summary Rx fail output. Alarm inputs software configurable for: a) All external patch, b) 1=Rx fail and 2-4 =external patch, c) 1=Rx fail and 2-4=OK, d) 1-4=Rx fail
ESC/Aux Ports	When the IDR option is fitted, independent ESC & Aux ports on the IDR option replace the single shared ESC/Aux port on the base unit.
ESC Port	RS232, RS422 or RS485 external interfaces or internal link to remote M&C port (software selected). No external cabling required between the ESC and M&C ports for M&C via ESC channel within the overhead. Other devices externally wired in parallel with M&C port can also be accessed remotely. Provides clock, data and sync (octet timing) lines.
IDR	Synchronous access to 8kbps IDR ESC. With the Async ESC option, async ESC access to the 8kbps IDR ESC is provided giving up to a 9600 baud async channel
Others	IBS and Closed Net Plus ESC facilities as before installation of IDR option, but now on ESC port on IDR card not shared ESC/Aux port of base unit.
Aux Port	RS232 or RS422 (user selectable). Provides clock and data lines.
IDR	Provides 32 or 64kbps access in place of one or both audio ESC channels.
IBS	Intelsat low rate ESC mode as previously but now via Aux port on IDR card not shared ESC Aux port of base unit. IDR option also adds sync IBS mode, configurable to use between 1/32nd and 21/32nd of the IBS overhead providing a full sync Aux port at between 0.2% and 4.3% of the main data rate. Aux port provides satellite timing information for P1500 slave Frequency Standard when not configured for Aux data access.

Common Specifications	
Parameter	QUANTUM Series Modem
Loop-backs	Interface Loop (Local and Remote) Framer Loop (Local) RS Loop (Local) FEC Loop (Local) Deframer/Framer Loop (Remote) Internal IF loopback (local, automatically matching Rx IF frequency to Tx)
Test Modes	Transmit CW (Pure Carrier) Transmit Alternate 1-0 Pattern Wideband spectrum analyzer display EZ Audio: 1kHz test tone on audio channels in IDR and P1348 emulation modes
Alarm Relays	4 Independent Change-Over Contacts: Unit Fault, Rx Traffic Fault Tx Traffic Fault, Deferred Alarm (backward alarm, BER or Eb/No below user set threshold)
Controller	Motorola PowerPC
Embedded Software	Revised embedded software may be downloaded into FLASH memory via Ethernet port with modem remaining in equipment rack.
Configuration Memories	>20 configurations can be stored and recalled from the front panel or remote M&C. Memories can be labelled with text string to aid identification.
User Interface	Clear and intuitive operator interface with plain English dialogue (other languages supported). Graphic display, backlight, high contrast, wide angle LCD. 17 key tactile full keyboard.
Remote Monitor And Control	For multi-drop applications, RS485 interface. For direct to PC applications, RS232 interface (front panel selectable). M&C port may be directly internally linked to ESC port for "over-the-satellite" M&C without cabling. Ethernet (10/100 BaseT) via RJ45, embedded Web server, SNMP agent V1, V2c and V3
Redundancy Features	1:1 redundancy controller built in. "Y" cables passively split data maintaining impedances. IF inputs/outputs are passively split, combined outside the units. Off-line unit tri-states data outputs and mutes Tx carrier.
Monitor	0-10V analogue output (Signal level, Eb/No, or Rx offset frequency) on Alarms & AGC connector.
Mechanical	1U chassis - 410mm deep, excluding front panel handles and rear panel connectors and fans.
Weight	3.5 kg
Power Supply	100-240VAC, +6%, -10%, 1A @100V, 0.5A @ 240V, 47-63Hz. Fused IEC connector (live and neutral fused). 48 Volts DC option
Safety	EN60950-1
EMC	EN55022 Class B (Emissions) EN55082 Part 1 (Immunity)
Environmental	Operating Temperature Range 0-50°C

AUPC Specifications	
Parameter	QUANTUM Series Modem
Modes of Operation	Monitor of distant Eb/No and BER only, full distant Eb/No maintenance. Unidirectional or Bi-directional operation.
Communication Link	Utilises asynchronous ESC channel on IBS/SMS, IDR and Closed Network, plus ESC carriers (ESC from 300 baud, i.e., overheads down to less than 1%). Maximum data rate 10 Mbps
User Parameters	Target Eb/No, positive power offset, negative power offset

EZ BERT Option Specifications	
Parameter	QUANTUM Series Modem
BER Channel	The BERT may operate through main traffic, ESC or Aux data channels, or outputted via the terrestrial interface. Use of ESC & Aux data channels allows continuous real traffic BER performance monitoring whilst the modem carries traffic.
Test Patterns	PRBS 2 <sup>N</sup> -1: N=6, 7, 9, 11, 15, 19, 20, 23. All 1s, All 0s, Alternate Patterns, Sparse Patterns, QRSS, User. Compatible with common stand-alone BER testers.
Results	Display of error count and average BER.
Autolog	Automatic logging of average BER and other parameters at regular intervals.

ODU facilities via IF interface	
Parameter	QUANTUM Series Modem
FSK Control Option	Allows monitor & control of a compatible Transceiver from the Modem, via the Tx IFL.

*Simple to use EZ-BERT BER Tester Option allows real time bit error measurements through traffic or ESC channel, or between the terrestrial ports.*

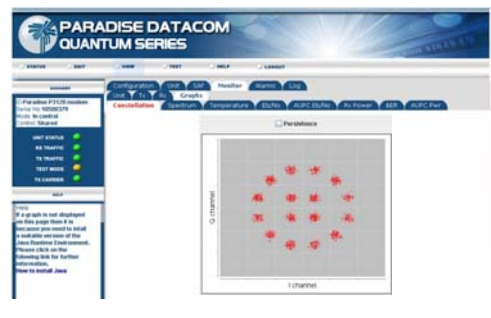
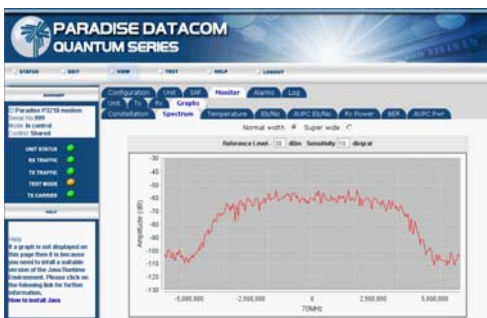

Fully configurable - only pay for what you need!

	Possible modes		Description
	SCPC	DVB-S2	
<b>PD20 IF Base Modem</b>	<input type="checkbox"/>	<input type="checkbox"/>	Wideband IF: 50-90 MHz & 100-180MHz in 100Hz steps, Closed Network modem, Closed Network plus ESC modem. Advanced ESC: Variable rate Async channel for Closed Net plus ESC operation. AUPC: Automatic Uplink Power Control (operates through ESC channel) Ethernet 10/100 BaseT on RJ45 for M&C. Remote Web Browser based monitoring tools (Spectrum Display, Constellation Monitor and link performance versus time) plus SMTP email client for status notification. DHCP allowing IP address to be allocated dynamically via external DHCP network server
	<input type="checkbox"/>	<input type="checkbox"/>	4.8kbps to 2,048kbps, 1bps variable rate, BPSK/QPSK/OQPSK Includes Viterbi FEC, Rates 1/2, 3/4 & 7/8 with k=7. Intelast Reed-Solomon Outer Codec to IESS 308. Unaccelerated Ethernet 10/100 Base T on RJ45 via traffic or overhead (Ethernet Bridging). Ethernet header compression at data rates up to 2Mbps. IEEE 802.1p QoS supporting choice of strict priority queuing or fair weighting queuing, IEEE 802.1q VLAN support.
	<input type="checkbox"/>	<input type="checkbox"/>	50kbps to 2,048kbps, 1bps variable rate in DVB-S2 mode, requires a DVB-S2 option
Adds Data Rates to 5Mbps	<input type="checkbox"/>	<input type="checkbox"/>	Extends base operation to 5Mbps
Adds Data Rates to 10Mbps	<input type="checkbox"/>	<input type="checkbox"/>	Extends 5Mbps operation to 10Mbps - requires 5Mbps option
Adds Data Rates to 20Mbps	<input type="checkbox"/>	<input type="checkbox"/>	Extends 10Mbps operation to 20Mbps - requires 5Mbps & 10Mbps options
Dynamic Routing	<input type="checkbox"/>	<input type="checkbox"/>	Adds Dynamic Routing, supports RIP, OSPF and BGP, plus 64 static routes - applies to base IP Traffic Interface or IP Traffic card.
TCP Acceleration	<input type="checkbox"/>	<input type="checkbox"/>	Point-to-Point and Point-to-Multipoint TCP/IP Acceleration to 10Mbps on base Ethernet port, subject to prevailing data rate limits - overcomes performance problems associated with TCP over satellite
Ethernet Bridging	<input type="checkbox"/>	<input type="checkbox"/>	Ethernet Bridging for Point-to-Multipoint operation when there is a non-satellite return path. Can be used with the base IP Traffic Interface or IP Traffic card
IP Traffic Shaping	<input type="checkbox"/>	<input type="checkbox"/>	Supports allocation of CIR and BIR plus priority for IP Streams identified by IP Address, Diffserv Class, IEEE 802.1p priority tag or MPLS EXP field. Can be used with the base IP Traffic Interface or the IP Traffic card.
Position 1 (must choose 1 option) <b>hardware option</b>	<input type="checkbox"/>	<input type="checkbox"/>	EIA 530 D25 DCE providing selectable RS422 / X.21 / V.35 / RS232, also balanced G.703 if G.703 option fitted
	<input type="checkbox"/>	<input type="checkbox"/>	IDR operation to IESS 308. Two audio ESC channels, synchronous 8kbps ESC, four form 'C' backward alarms & Async ESC access to IDR 8k sync channel - includes EZ Audio test tone generator
	<input type="checkbox"/>	<input type="checkbox"/>	Sat-Abis Interface card (DOUBLE HEIGHT CARD - negates fitting any option in position 2) One E1/fractional E1 port on RJ45 enabled - maximum aggregate traffic rate 2048kbps in all cases
	<input type="checkbox"/>	<input type="checkbox"/>	Blank Panel
Position 1 Sat-Abis card options - can only be used with the Sat-Abis Interface card	<input type="checkbox"/>	<input type="checkbox"/>	Adds Port 2, E1/fractional E1 on RJ45, requires Sat-Abis Interface in position 1
	<input type="checkbox"/>	<input type="checkbox"/>	Adds Port 3, E1/fractional E1 on RJ45, requires Sat-Abis Interface in position 1 plus Port 2 activated
	<input type="checkbox"/>	<input type="checkbox"/>	Adds Port 4, E1/fractional E1 on RJ45, requires Sat-Abis Interface in position 1 plus Ports 2 and 3 activated
Position 2 (must choose 1 option) <b>hardware option</b>	<input type="checkbox"/>	<input type="checkbox"/>	LVDS on D25
	<input type="checkbox"/>	<input type="checkbox"/>	EIA 530 D25 DCE providing selectable RS422/X.21/V.35/RS232, also balanced G.703 if G.703 option fitted
	<input type="checkbox"/>	<input type="checkbox"/>	HSSI on HD50 50-way SCSI-2 connector
	<input type="checkbox"/>	<input type="checkbox"/>	IP Traffic card providing TCP acceleration to 16,896kbps (P-P and P-MP), subject to prevailing data rate limits, also provides HTTP Acceleration by prefetching webpage inline objects to reduce webpage download time - requires either Blank Panel or EIA 530 in position 1
	<input type="checkbox"/>	<input type="checkbox"/>	Eurocom D1 on D25 male - pin compatible with P300 Eurocom
	<input type="checkbox"/>	<input type="checkbox"/>	Eurocom D1 / EIA530 on D25 female
	<input type="checkbox"/>	<input type="checkbox"/>	Quad E1 Multiplexer with 1 x RJ45 port enabled plus integral G.703 and Drop & Insert included - includes IBS/SMS satellite framing
<input type="checkbox"/>	<input type="checkbox"/>	Blank Panel	
Position 2 Quad E1 Mux options - only used with Quad E1 Mux card	<input type="checkbox"/>	<input type="checkbox"/>	Adds Port 2 with Drop & Insert to Quad E1 card - requires Quad E1 Mux plus data rate option to 5Mbps
	<input type="checkbox"/>	<input type="checkbox"/>	Adds Port 3 with Drop & Insert to Quad E1 card - requires Quad E1 Mux with Port 2 option plus 5Mbps and 10Mbps data rate options
	<input type="checkbox"/>	<input type="checkbox"/>	Adds Port 4 with Drop & Insert to Quad E1 card - requires Quad E1 Mux with Port 2 option & Port 3 option plus 5Mbps and 10Mbps data rate options
	<input type="checkbox"/>	<input type="checkbox"/>	MultiMux - Allows base IP traffic and/or EIA 530 traffic, if EIA 530 interface fitted, to be used in place of 1 or 2 x Quad E1 ports. Each MultiMux port limited to 2,048kbps traffic rate, and aggregate traffic rate limited to prevailing data rate limit.
Position 2 IP Traffic card options	<input type="checkbox"/>	<input type="checkbox"/>	Adds TCP acceleration up to 20Mbps on IP Traffic card, subject to prevailing data rate limits - requires IP Traffic card
	<input type="checkbox"/>	<input type="checkbox"/>	Encapsulation of IP packets and Ethernet frames over DVB uses Paradise eXtreme Protocol (PXE), Multi Protocol Encapsulation (MPE) or Ultra Lightweight Encapsulation (ULE) protocols.
Position 3 (only for G.703 traffic) <b>hardware option</b>	<input type="checkbox"/>	<input type="checkbox"/>	No BNC traffic interface - if no G.703 option
	<input type="checkbox"/>	<input type="checkbox"/>	2 x BNC sockets providing unbalanced G.703 75 ohm - supplied only with G.703 option
DVB-S2 Modulation & Coding <b>hardware options</b>	<input type="checkbox"/>	<input type="checkbox"/>	DVB-S2 CCM Tx - includes QPSK, 8PSK & 16APSK for DVB-S2 use only, includes also LDPC-BCH Error Correction for DVB-S2 only. Must specify IP Traffic card if IP Traffic required.
	<input type="checkbox"/>	<input type="checkbox"/>	DVB-S2 CCM Rx - includes QPSK, 8PSK & 16APSK for DVB-S2 use only, includes also LDPC-BCH Error Correction for DVB-S2 only. Must specify IP Traffic card if IP Traffic required. <b>Includes DVB-S2 ACM Receive function - when used, requires the other end of the link to have DVB-S2 ACM Transmit.</b>
DVB-S2 VCM Multistreaming	<input type="checkbox"/>	<input type="checkbox"/>	VCM point-to-multipoint multistreaming allows the FEC rate and modulation to be selected for individual remotes
DVB-S2 ACM Transmit Automatic Coding and Modulation - requires DVB-S2 CCM Tx <b>When used, requires the other end of the link to have DVB-S2 CCM RX including DVB-S2 ACM Receive.</b>	<input type="checkbox"/>	<input type="checkbox"/>	DVB-S2 ACM Transmit to 2Mbps
	<input type="checkbox"/>	<input type="checkbox"/>	DVB-S2 ACM Transmit extension to 5Mbps, requires DVB-S2 Transmit to 2Mbps
	<input type="checkbox"/>	<input type="checkbox"/>	DVB-S2 ACM Transmit extension to 10Mbps, requires DVB-S2 Transmit to 2Mbps & 5Mbps
	<input type="checkbox"/>	<input type="checkbox"/>	DVB-S2 ACM Transmit extension to 20Mbps, requires DVB-S2 Transmit to 2Mbps & 5Mbps & 10Mbps, subject to prevailing data rate limits
Low Rate TPC 2nd Generation Turbo 10Mbps maximum Subject to prevailing data rate limits	<input type="checkbox"/>	<input type="checkbox"/>	Rates 5/16, 21/44, 0.493, 2/3, 3/4, 0.789, 7/8 Paradise (low latency) in BPSK, QPSK, OQPSK Rate 7/8 in QPSK, OQPSK Rate 0.93 Paradise in QPSK, OQPSK Rates 3/4, 7/8, 0.93 Paradise in 8PSK - requires 8PSK option Rates 3/4, 7/8, 0.93 Paradise in 16QAM - requires 16QAM option
	<input type="checkbox"/>	<input type="checkbox"/>	Rates 5/16, 21/44, 0.493, 2/3, 3/4, 0.789, 7/8 Paradise (low latency) in BPSK, QPSK, OQPSK Rate 7/8 in QPSK, OQPSK Rate 0.93 Paradise in QPSK, OQPSK Rates 3/4, 7/8, 0.93 Paradise in 8PSK - requires 8PSK option Rates 3/4, 7/8, 0.93 Paradise in 16QAM - requires 16QAM option
	<input type="checkbox"/>	<input type="checkbox"/>	Rates 5/16, 21/44, 0.493, 2/3, 3/4, 0.789, 7/8 Paradise (low latency) in BPSK, QPSK, OQPSK Rate 7/8 in QPSK, OQPSK Rate 0.93 Paradise in QPSK, OQPSK Rates 3/4, 7/8, 0.93 Paradise in 8PSK - requires 8PSK option Rates 3/4, 7/8, 0.93 Paradise in 16QAM - requires 16QAM option
	<input type="checkbox"/>	<input type="checkbox"/>	Rates 5/16, 21/44, 0.493, 2/3, 3/4, 0.789, 7/8 Paradise (low latency) in BPSK, QPSK, OQPSK Rate 7/8 in QPSK, OQPSK Rate 0.93 Paradise in QPSK, OQPSK Rates 3/4, 7/8, 0.93 Paradise in 8PSK - requires 8PSK option Rates 3/4, 7/8, 0.93 Paradise in 16QAM - requires 16QAM option
Sequential FEC Limited to 2,048kbps maximum	<input type="checkbox"/>	<input type="checkbox"/>	Rates 1/2, 3/4, 7/8 in BPSK, QPSK, OQPSK

Configuration options continue on next page.



Fully configurable - only pay for what you need!

	Possible modes		Description
	SCPC	DVB-S2	
FastLink Low Latency LDPC subject to prevailing data rate limits	•		FastLink LDPC ready (hardware option) - requires additional FastLink LDPC software features below
	•		FastLink LDPC up to 1Mbps, supports BPSK and QPSK, also supports 8PSK - requires 8PSK option, FastLink 8QAM - requires FastLink 8QAM option, FastLink 16APSK - requires FastLink 16APSK option, FastLink 32APSK - requires FastLink 32APSK option, FastLink 64QAM - requires FastLink 64QAM option, and 16QAM - requires 16QAM option. <b>Must have FastLink LDPC ready option.</b>
	•		FastLink LDPC extension to 2.5Mbps - requires FastLink LDPC to 1Mbps
	•		FastLink LDPC extension to 5Mbps - requires FastLink LDPC to 1Mbps and extension to 2.5Mbps
	•		FastLink LDPC extension to 10Mbps - requires FastLink LDPC to 1Mbps plus extension to 2.5Mbps and extension to 5Mbps
	•		FastLink LDPC extension to 20Mbps - requires FastLink LDPC to 1Mbps plus extension to 2.5Mbps, extension to 5Mbps and extension to 10Mbps
FastLink 8QAM	•		FastLink 8QAM requires FastLink LDPC
FastLink 16APSK	•		FastLink 16APSK - requires FastLink LDPC
FastLink 32APSK	•		FastLink 32APSK - requires FastLink LDPC
FastLink 64QAM	•		FastLink 64QAM - requires FastLink LDPC
8PSK Including TCM	•		Rate 2/3 8PSK Pragmatic TCM to IESS 310 8PSK Turbo available - requires 2nd Generation Turbo FEC option
16QAM	•		16QAM - requires either 2nd Generation Turbo FEC option or LDPC option
IBS / SMS	•	•	Satellite Framing to IESS 309 with low rate Intelsat ESC (to IESS 403) & High Rate IBS/SMS ESC
Audio Channels	•	•	P1348 Emulation mode for IBS 64kbps carrier (2xaudio) or 128kbps (2xaudio + 64kbps data) - requires IBS / SMS & IDR options
G.703	•	•	E1, T1, E2, T2 interfaces ( <b>hardware option</b> ) - requires either EIA 530 or BNC sockets for traffic
Drop / Insert including Extended D/I	•	•	T1/E1 linear order Drop/Insert, plus independent timeslot re-ordering on Tx & Rx. Signalling (E1 CAS & T1 RBS). Rx Partial Insert for multi-destination working, Timeslot ID maintenance for N=1 to 31 with IBS / SMS or Closed Net plus ESC. Drop/Insert can operate with any interface, although G.703 is typically used (requires G.703 option if used in G.703 mode)
G.703 Clock Extension	•	•	Provides a stable G.703 E1 or T1 reference clock over satellite when traffic is NOT E1 or T1
Advanced AUX	•	•	Variable rate synchronous Aux channel for IBS / SMS - requires IBS / SMS option IDR 32/64kbps in place of one/both audio ADPCM ESC channels - requires IDR option
Custom	•	•	Custom RS Outer Codec values of n, k and interleaver depth. Custom IBS / SMS modes, allocation of overhead between ESC and Aux channels in IBS / SMS, custom backward alarms in IBS / SMS, and Closed Net plus ESC - requires IBS/SMS option. Custom IDR mode - requires IDR option.
EZ BERT - PRBS Tester	•	•	Internal Bit Error Rate Tester (BERT) can run through main data channel, or ESC/Aux channels, or output/input via the terrestrial interface
OM-73	•		OM-73 Scrambling, symbol mapping and Viterbi compatibility
48V DC Input	•	•	48V DC Primary power input in place of 100-240V AC input ( <b>hardware option</b> )
FSK Control Option on IF	•	•	Allows monitor & control of a compatible Transceiver from the Modem, via the Tx IFL ( <b>hardware option</b> )
Adaptive Signal Predistorter	•		Use with 16QAM to relax HPA backoff by up to 1.6dB. Compensates for HPA non-linearities in ground segment and/or transponder. Requires 16QAM option.
Tx Only operation	•	•	Transmit functions only
Rx Only operation	•	•	Receive functions only
Paired Carrier (carrier re-use) subject to prevailing modem data rate limits. Minimum occupied band- width limit of 150kHz	•	•	P3603 - Paired Carrier Ready, allows carriers to be overlapped thereby reducing the required satellite bandwidth. <b>(hardware option)</b> - requires additional cumulative software options below depending upon data rate required
	•	•	Paired Carrier up to 512kbps traffic rate - requires Paired Carrier Ready option
	•	•	Extends Paired Carrier up to 1024kbps traffic rate - requires 512kbps option
	•	•	Extends Paired Carrier up to 2.5Mbps traffic rate - requires 1024kbps option
	•	•	Extends Paired Carrier up to 5Mbps traffic rate - requires 2.5Mbps option
	•	•	Extends Paired Carrier up to 10Mbps traffic rate - requires 5Mbps option
Ruggedisation	•	•	Extends Paired Carrier up to 15Mbps traffic rate - requires 10Mbps option
	•	•	Extends Paired Carrier up to 20Mbps traffic rate - requires 15Mbps option
	•	•	Adds extra ruggedisation for hostile environments

Paradise Datacom reserves the right to change specifications of products described in this document at any time without notice and without obligation to notify any person of such changes. Refer to the website or contact Sales or Customer Service for the latest product information.