



**Indoor (1RU) Dual Block Up Converter**

### Description

Introducing the RBC Series of frequency converters from Paradise Datacom. The RBC is packaged in a standard 19" EIA indoor rack mount chassis and is configurable with C-, X- and Ku-Band RF modules. The RBC chassis design allows RF modules to be removed and replaced from the rear panel without the need to interrupt chassis power.

Since one common chassis supports all frequency bands, it can be fitted with any combination of RF modules, which includes mixing up-converters and down-converters. The on-board software will sense and determine the frequency and type of module automatically. In addition, internal redundancy logic allows each chassis to be operated in single, dual or 1:1 redundant modes.

The Up-converter translates an L-band input signal anywhere within the range of 950-2050 MHz to a C-, X- or Ku-Band output frequency depending on which module is installed. Conversely, the Down-converter translates a C-, X- or Ku-band input signal to an output frequency in the range of 950 to 2050 MHz.

The converter architecture of the RBC is based upon Paradise Datacom's highly successful zBUC L-band RF converter module used throughout our line of Solid State Power Amplifiers (SSPA). The high-stability on-board oscillator is referenced to an internal 10 MHz source or will accept external 5 and 10 MHz sources.

Remote control and monitoring is available via the rear panel parallel I/O, serial I/O or Ethernet M&C ports using Paradise Datacom's Universal Monitor and Control Software.

### FEATURES

- Supports all Satellite Frequency Bands
- 1:1 Redundancy
- Single 1RU chassis
- Hot-swap converter modules
- Low phase noise
- High Stability Oscillator
- Remote Monitoring
- Summary alarm

### OPTIONS

- Single Upconverter
- Single Downconverter
- Dual Upconverter
- Dual Downconverter
- Up/Downconverter
- Internal (10 MHz) or External (5 or 10 MHz) Reference
- Adjustable Gain Control
- Inverted Spectrum for C-Band Upconverters
- N-type RF Connector

### SPECIFICATIONS

- Conversion Gain 25 dB
- Output power ( $P_{1dB}$ ) 15dBm
- Spurious -65 dBc
- Phase Noise Exceeds IESS Standards

### Upconverter Specifications

PARAMETER	LIMITS	UNITS
Input Frequency Range	Output Frequency Range	
950 to 1525	5850 to 6425	MHz
950 to 1750	5850 to 6650	MHz
950 to 1350	6700 to 7100	MHz
950 to 1450	7900 to 8400	MHz
950 to 1450	12750 to 13250	MHz
950 to 1700	13750 to 14500	MHz
950 to 1450	14000 to 14500	MHz
950 to 2050	17300 to 18400	MHz
Input Return Loss	15	dB (min.)
Output Return Loss	18	dB (min.)
Gain	25	dB
Variable Gain Control (option)	20	dB (max.)
Nominal Input Level	-25	dBm
Image Rejection	60	dB
Carrier Mute	60	dB
Output Power (P1dB)	15	dBm
Amplitude Response (36/40 MHz)	± 0.5	dB
Amplitude Response (Band)	± 1	dB
Gain Stability/24 hours	± 0.25	dB
3rd Order Intercept	18	dBm
Signal Related spurious	-65	dBc
Signal Independent	-75	dBm
Spectrum Sense	Non-Inverted	
Spectrum Sense (5850 - 6425 MHz Output Frequency)	Inverted Option	
Internal Reference	YES	
External Reference Detect	YES	
Frequency Stability (temperature)	± 2x10 <sup>-8</sup>	
Frequency Stability (aging)	± 5x10 <sup>-9</sup>	per day
Input Impedance	50	ohms
Input Connector	N (f)	
Output Impedance	50	ohms
Output Connector	SMA (f)	Standard
External Reference (10 MHz) [Optional 5 MHz]	0 ± 3	dBm
Phase Noise Performance	Exceeds IESS	
Noise Figure (maximum gain)	15	
Summary Alarm		
Connectors		
L-Band	N (F)	
RF	SMA (F)	
Optional RF	N (F)	
Reference	BNC (F)	
Comm	DB-9 (F)	
Fault	DB-9 (M)	
Ethernet	RJ45	

### Downconverter Specifications

PARAMETER	LIMITS	UNITS
Output Frequency Range	Input Frequency Range	
950 to 1750	3400 to 4200	MHz
950 to 1450	7250 to 7750	MHz
950 to 1950	10700 to 11700	MHz
950 to 1700	10950 to 11700	MHz
950 to 1950	11200 to 12200	MHz
950 to 1750	11700 to 12500	MHz
950 to 1500	12200 to 12750	MHz
Input Return Loss	20	dB (min.)
Output Return Loss	15	dB (min.)
Gain	35	dB (min.)
Variable Gain Control (option)	20	dB (max.)
RF Input Power	-25	dBm (max.)
Output Power (P1dB)	15	dBm
Amplitude Response (40 MHz)	± 0.5	dB
Amplitude Response (Band)	± 1	dB
Gain Stability/24 hours	± 0.25	dB
3rd Order Intercept	-60	dBc
Carrier Spurious	-60	dBc
Spectrum Sense	Non-Inverted (except C-Band)	
Frequency Stability (temperature)	± 2x10 <sup>-8</sup>	
Frequency Stability (aging)	± 5x10 <sup>-9</sup>	per day
Input Impedance	50	ohms
Input Connector	SMA (f)	
Output Impedance	50	ohms
Output Connector	N-Female	
External Reference (10 MHz)(5 MHz Optional)	0 ± 3	dBm
Phase Noise Performance	Exceeds IESS	
Noise Figure (max. gain)	15	
LO Leakage	-80	dBm
Image Rejection	-60	dB (min.)
Connectors		
L-Band	N (F)	
RF	SMA (F)	
Optional RF	N (F)	
Reference	BNC (F)	
Comm	DB-9 (F)	
Fault	DB-9 (M)	
Ethernet	RJ45	



### Part Number Configuration - Dual Upconverter

**R B C 1** | | | | | | | | | | **X X X**

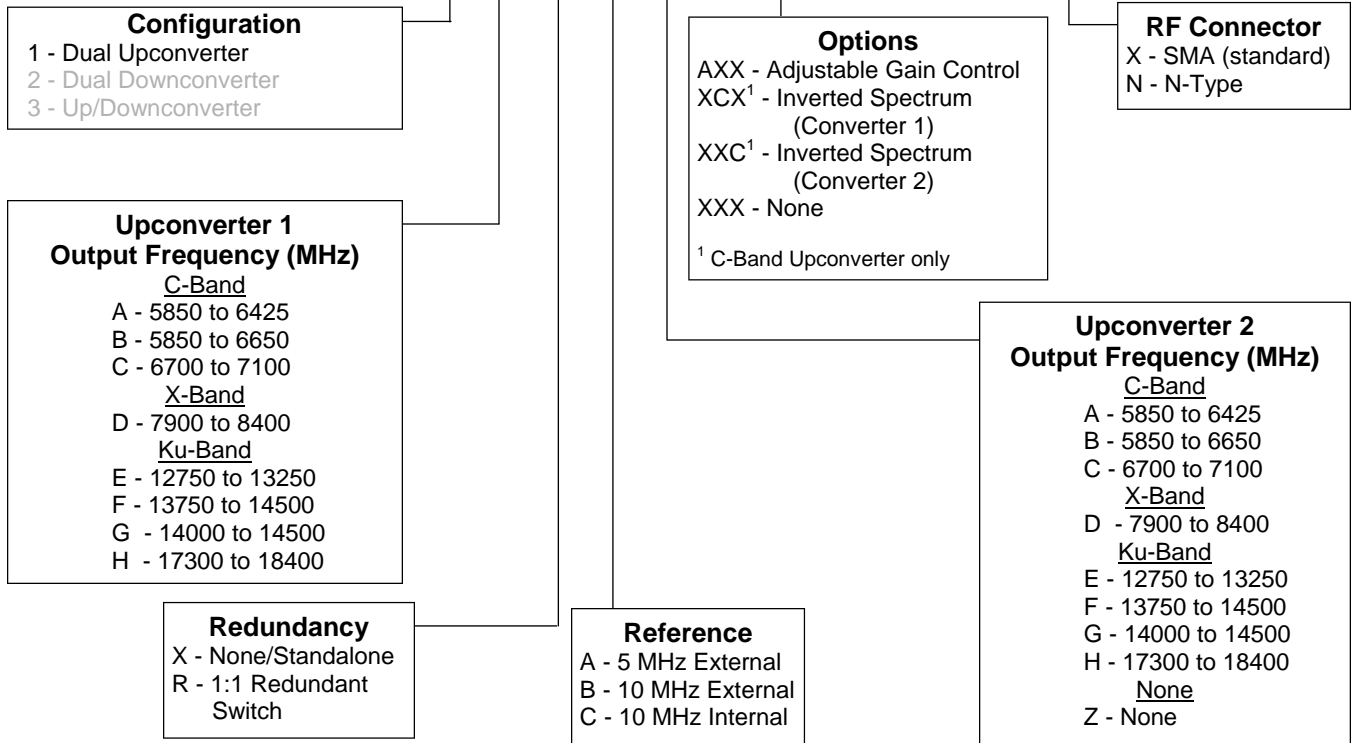

### Part Number Configuration - Dual Downconverter

**R B C 2** | | | | | | | | | | **X X X X X**

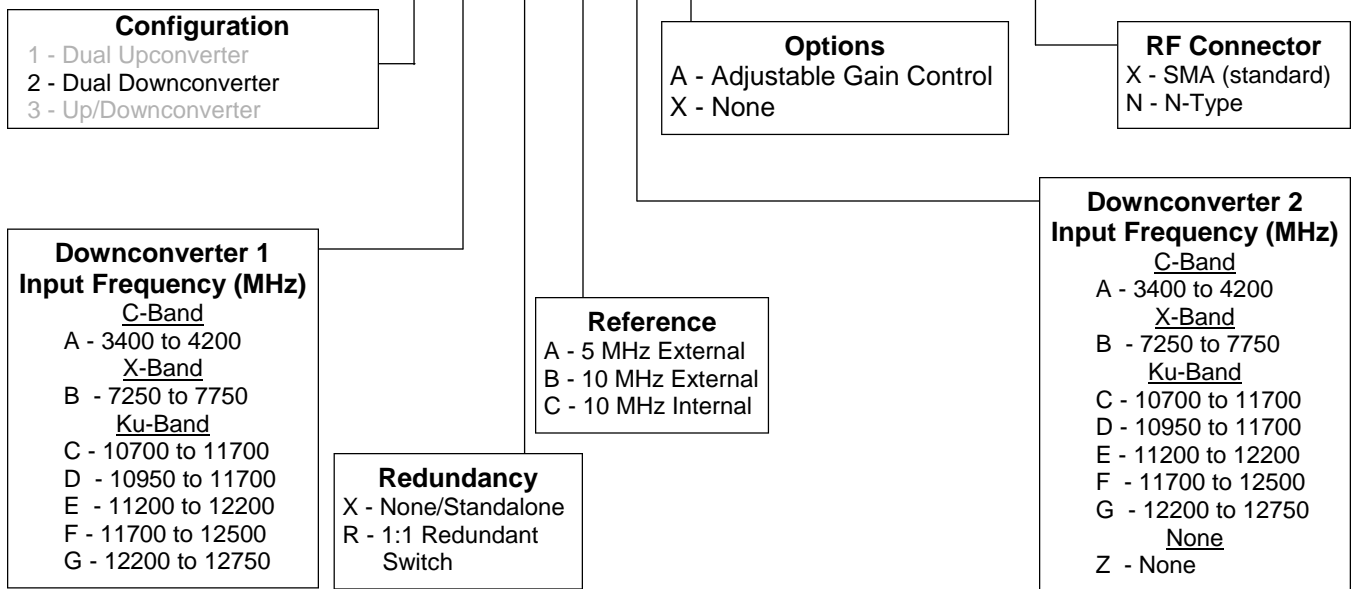

### Part Number Configuration - Up/Downconverter

**R B C 3 X X X X X**

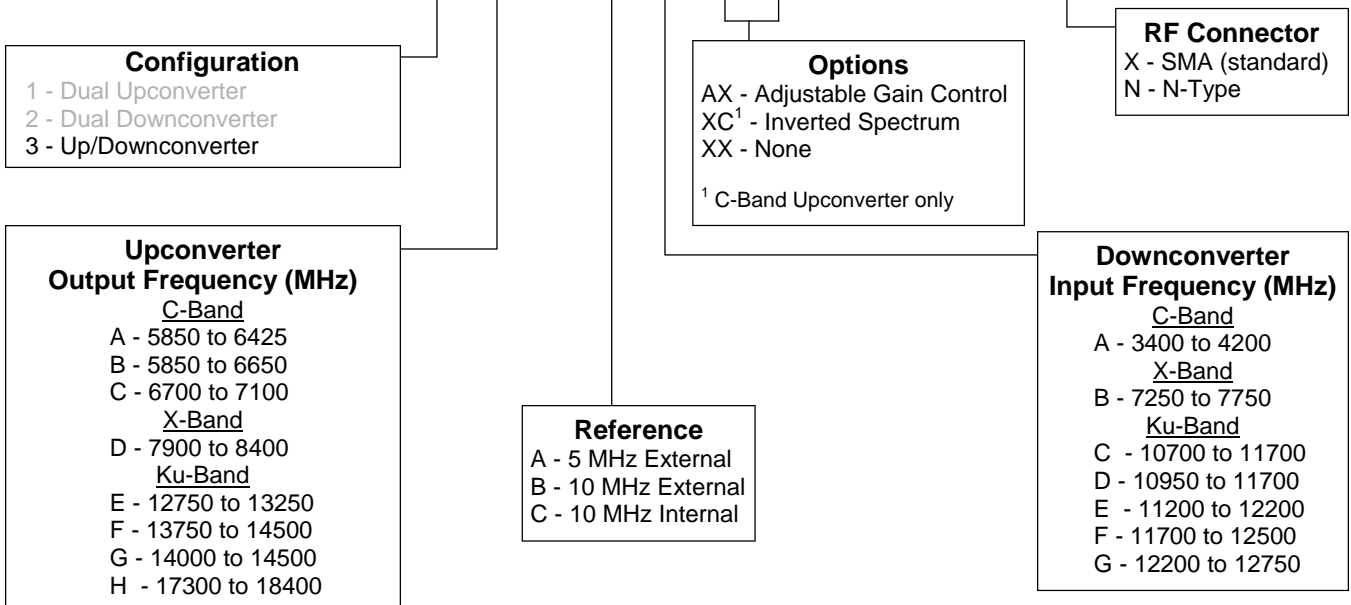

### Part Number Configuration - Spare Rack Converter Module

**R B C M X X X X X**

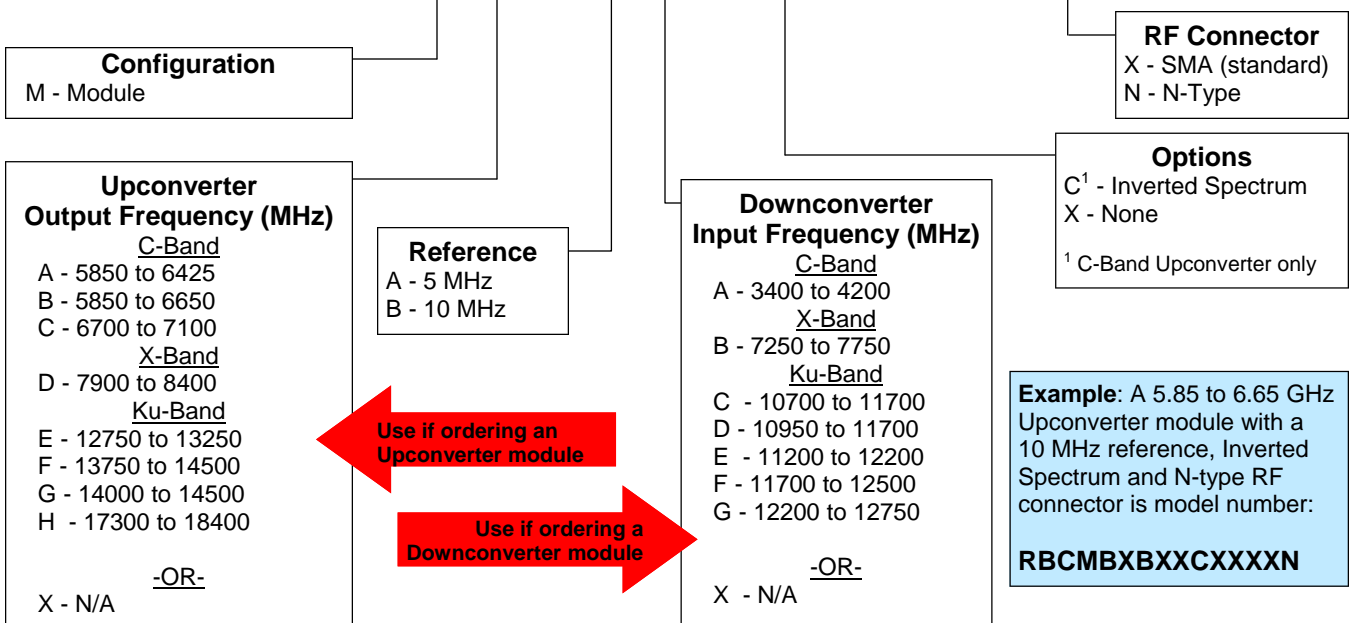

Specifications listed in this datasheet are subject to change without notice.